

**HD9008..., HD9009... SERIES
TEMPERATURE AND HUMIDITY TRANSMITTERS
HD9007... - MULTIPLE RADIATION SHIELD**



HD9008... and HD9009... are single block RH and temperature (or only RH or only temperature) microprocessor transmitters, temperature configurable.

They are available in different versions:

- HD9008TRR: 2-wire with 4...20 mA output for RH and temperature
- HD9008T7AC: 2-wire with 4...20 mA output (only temperature)
- HD9008T7S: with RS485 MODBUS-RTU output
- HD9009TRR: 0...1 V standard voltage output (other outputs available on demand) for RH and temperature

Sensors

The humidity sensor is a capacitor which dielectric is made up by an hygroscopic polymer. As water dielectric constant is approximately 80, you'll get a strong change in capacity as the humidity content of this polymer changes. The advantages of this kind of sensor are: good linearity, insensitivity to temperature changes, fast response time and long-lasting life. The sensor temporary loses its accuracy if some condensation develops on its surface (the transmitted value is higher than the real one because of an increase in effective capacity).

The temperature sensor is a Platinum resistance thermometer (100Ω @ 0 °C). The Pt100 resistance variation is transformed into a current or voltage signal, linear to temperature.

Installation and assembly

Accuracy in measuring does not depend on the transmitter position. However, it is suggested to install the transmitter with the sensor faced downwards (where possible) to reduce dust deposit on the sensor protection filter. The transmitter shall not be mounted next to doors, in draughtiness, in areas with scarce air circulation, or near a heat source, as heating air involves a decrease of relative humidity (the quantity of available water vapour being equal).

Ensure that the sensor is compatible with the atmosphere where it is installed.

Follow these procedures to access the transmitter terminal board (see picture below):

- unscrew grommet "A";
- take off rubber bulb "B" and unscrew bottom "C";
- insert the cable through A, B and C elements and connect it to the terminal board;
- hold the cable firmly while screwing grommet "A" to avoid twisting.

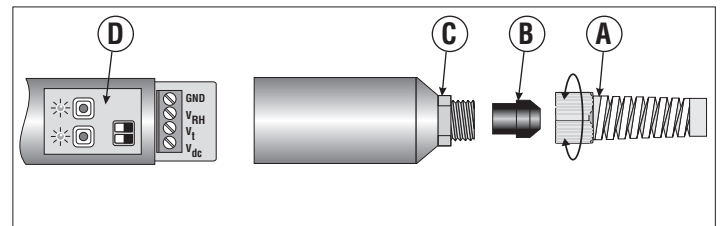

Signal Transmission - models with analog output

The electronic circuit design provides the signal to increase linearly as humidity and temperature raise.

In presence of cables transmitting high currents or machines causing electromagnetic noises, the transmitter connection cables have to be placed in a separate raceway, or far from them, to prevent these noises. It is always recommended to use a shielded cable for the connections of instruments.

Connections

Fig.2 and fig.3 show the connection diagrams of the models with analog output. R_{RH} and R_{c} represent the current input of any device connected to the 4...20 mA loop, that is: an indicator, a controller, a data logger or a recorder. In fig.2, $V_{in}\%RH$ and $V_{in}^{\circ C}$ symbols have the same meaning. Compared to the figures shown, the wiring diagram of the HD9008T7AC model has only the temperature output.

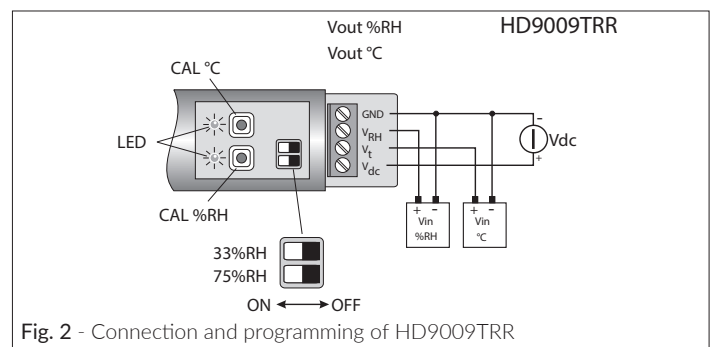

Fig. 2 - Connection and programming of HD9009TRR

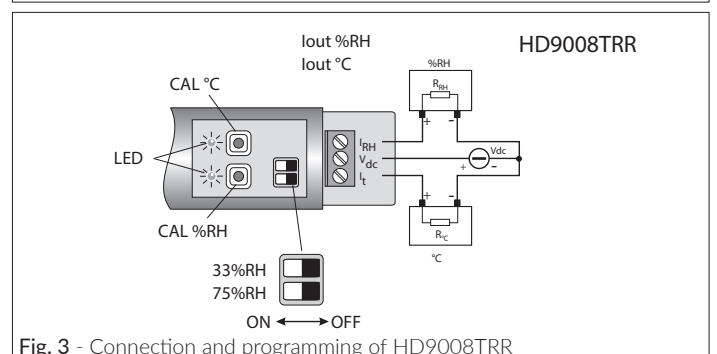

Fig. 3 - Connection and programming of HD9008TRR

Programming

The instrument can be reprogrammed by means of a key, and no jumper or potentiometer actions are required.

Humidity Sensor Calibration

The humidity input can be recalibrated by using two saturated solutions: the first one at 75%, the second one at 33%; the 0% RH...100% RH relative humidity range is fixed, 4 mA (or 0 Vdc) correspond to 0% RH, 20 mA (or 1 Vdc) correspond to 100% RH.

The user can re-calibrate the RH probe holding the 0%...100% RH range.

The following accessories are needed

- for HD9008TRR: a 10...30 Vdc continuous voltage power supply, a precision ammeter with a 0...25 mA min. range.
- for HD9009TRR: a 5...35 Vdc continuous voltage power supply, a precision voltmeter with a 0...1 Vdc min. range.

The calibration of the humidity sensor is carried out at two fixed points: at 75.4% RH (**always as first point**) and at 33% RH (**second point**).

Procedure

1. To access the panel board, unscrew grommet "A" (see fig. 1) and hold the cable firmly to avoid twisting. Take off the rubber bulb and unscrew the bottom of the instrument.
2. Connect the wires to provide the instrument with power supply, as shown in the connection diagrams of fig. 4 (HD9008TRR) and of fig.5 (HD9009TRR).
3. Insert the probe in the container with the saturated solution at 75% RH and wait 30 minutes at least. Probes and solutions have to be at the same temperature.
4. Turn 75% RH dip-switch on ON.
5. Press the CAL% RH key and hold it down for 5 seconds, at least, until the corresponding LED does not flash. Now the key can be released: the LED will remain on. A built-in sensor compensates the temperature difference of the solution compared with 20°C.
6. Turn the 75% RH dip-switch on OFF.
7. Put the probe in the container with the saturated solution at 33%RH and wait for 30 minutes, at least. Probes and solutions have to be at the same temperature.
8. Turn the 33% RH dip-switch on ON.
9. Press the CAL% RH key and hold it down for 5 seconds, at least, until the corresponding LED is not off. Now the key can be released.

If the solution is at 20 °C, the output will equal 9.28 mA (in HD9008TRR) and 0.330 V (in HD9009TRR).

10. Turn the 33% RH dip-switch on OFF again.

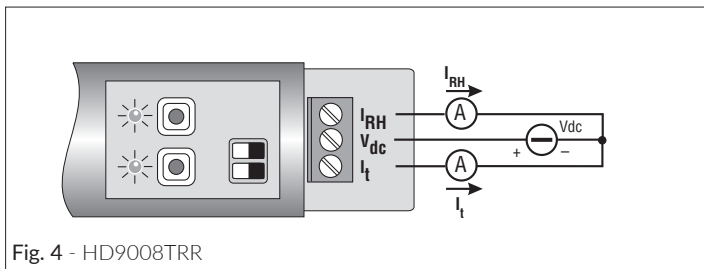

Fig. 4 - HD9008TRR

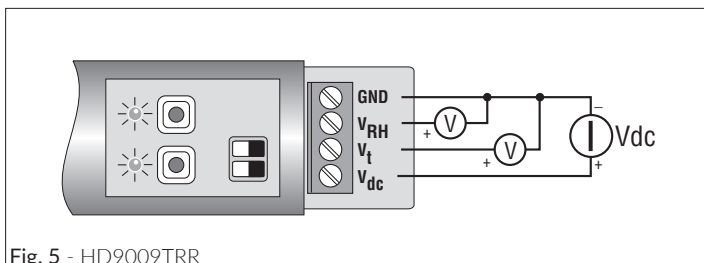

Fig. 5 - HD9009TRR

11. Re-close the instrument: re-screw the bottom, put the rubber bulb again at its place and screw the grommet: hold the cable firmly to avoid twisting it.

12. The calibration of the RH probe is finished.

Saturated reference solutions are available for RH calibration. Calibration is suggested every 12/18 months for instruments with continuous operation, according to the environment they are working in. Check that the sensor and the atmosphere where it is employed be compatible, above all in case of aggressive environments (they might corrode the sensor).

Note: the first calibration point has to be always at 75% RH

Programmig of temperature operating range (models HD9008TRR, HD9008T7AC, HD9009TRR)

Temperature standard configuration is -40...+80 °C corresponding to 4...20 mA (for HD9008TRR and HD9008T7AC) and 0...1 Vdc (for HD9009TRR). The user can configure the temperature output in ranges different from the standard one. These should however be included in the -40 °C...+80 °C range with a minimum amplitude of 25 °C. Two LEDs give alarm indications (temperature exceeding set range, sensor breakage or short-circuit) and help the operator when programming.

The following accessories are needed

- for HD9008TRR and HD9008T7AC models: a 10...30 Vdc continuous voltage power supply, a precision ammeter with 0...25 mA minimum range.
- for HD9009TRR: a 5...35 Vdc continuous voltage power supply, a precision voltmeter with 0...1 Vdc minimum range.
- Pt100 simulator or a set of precision resistances.

Procedure

1. To access the panel board, unscrew grommet "A" (see figure 1) and hold the cable firmly to avoid twisting. Take the rubber bulb off and unscrew the bottom of the instrument.
2. Unscrew the sensor protection filter.
3. Unsolder the Pt100 sensor (the narrowest one) and in place of it, solder the output wires of a Pt100 simulator or those of a precision resistance, as shown in figures 6 and 7. Then wait a few seconds for the junction to get cold.
4. Set the Pt100 simulator at the temperature corresponding to the scale lower value. For example, if you want to configure the -10 °C...+80 °C range, the simulator has to be set at -10 °C; the equivalent resistance value will be 96.09Ω. If the calibration is carried out with a fixed resistance, connect a 96.09Ω fixed resistance to the terminals to which the sensor was soldered.
5. Wait 10 seconds until the measurement becomes steady, press the "CAL °C" key (calibration) and hold it down for minimum 5 seconds, until the LED first flashes (once) and then remains on.
6. Set the Pt100 simulator at the temperature value corresponding

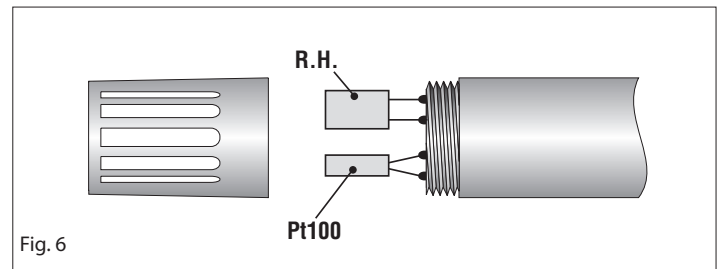

Fig. 6

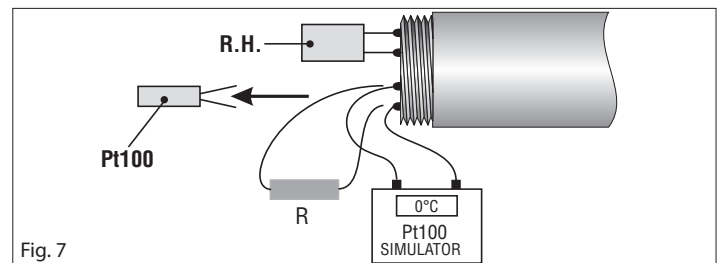

Fig. 7

to the full scale. According to the above example, the simulator will be set at +80 °C; the equivalent resistance value will be 130.89Ω; if the calibration is carried out with a fixed resistance, a 130.89Ω fixed resistance will have to be connected to the terminals to which the sensor was soldered.

7. Wait 10 seconds until the measurement becomes steady, press the "CAL °C" key (calibration) and hold it down for minimum 5 seconds, until the LED is off. When you release the key, the LED will flash twice to confirm that programming took place.
8. Check that the configuration corresponds to the requested specifications, by setting the simulator (or connecting the precision resistances) at the values corresponding to the lower and full scale value and by checking the output with the ammeter (HD9008TRR-HD9008T7AC) or with the voltmeter (HD9009TRR).
9. Solder again the temperature sensor.

10. Insert again the sensor protection filter, screw the bottom, put the rubber bulb again at its place and screw the grommet holding the cable firmly to avoid twisting.

11. The temperature output programming is over. An out-of-standard temperature operating range can be requested when placing the order.

Note: probes work in the -40 °C...+80 °C temperature range. Outside this range data are not correct; electronics is designed to operate in this range.

Technical specifications					
		HD9008TRR	HD9008T7S	HD9008T7AC	HD9009TRR
Operating temperature		-40...+80 °C			
Output		analog	RS485 MODBUS-RTU	analog	analog
Power Supply		10...30 Vdc	5...30 Vdc	10...30 Vdc	5...35 Vdc
HUMIDITY	Sensor	Capacitive	/		Capacitive
	Measuring Range	0...100 %RH	/		0...100 %RH
	Accuracy	±1.5 % (0...90 %RH) / ±2 % (90...100 %RH) @ T=15...35 °C ± (1.5 + 1.5% of the measure)% @ T= remaining range	/		±1.5 % (0...90 %RH) / ±2 % (90...100 %RH) @ T=15...35 °C ± (1.5 + 1.5% of the measure)% @ T= remaining range
	Response time (t ₆₃ , 10 -> 80 %RH)	<10 s (with P1 standard filter; air speed=2 m/s @ constant temp.)	/		<10 s (with P1 standard filter; air speed=2 m/s @ constant temp.)
	Output signal	0% RH = 4.0 mA 100% RH = 20.0 mA	/		0 %RH = 0.00 Vdc 100 %RH = 1.00 Vdc (*)
	Load Resistance	$R_{Lmax} = \frac{(Vdc - 10)}{22mA}$	/		$R_{minMIN} = 10k\Omega$
TEMPERATURE	Measuring Range - Standard Configuration (**)	-40...+80 °C			
	Accuracy	± 0.2 °C ± 0.15 % of the mesure			
	Response time (t ₆₃)	<15 s (with P1 filter)			
	Output Signal	-40 °C = 4.0 mA +80 °C = 20.0 mA	MODBUS	-40 °C = 4.0 mA +80 °C = 20.0 mA	-40°C = 0.00 Vdc +80°C = 1.00 Vdc (*)
	Load Resistance	$R_{Lmax} = \frac{(Vdc - 10)}{22mA}$	/	$R_{Lmax} = \frac{(Vdc - 10)}{22mA}$	$R_{minMIN} = 10k\Omega$
Dimensions (excluding cable gland)		Ø 26 x 185 mm			
Protection Degree		IP65			
CABLE DIMENSIONS	Maximum Length for analog output connection (***)	200 m	depending on Baud Rate and wire gauge	200 m	10 m
	Wire minimum section	20 AWG - 0.5 mm ²			
	Cable maximum diameter	Ø 5 mm			
(*) For HD9009TRR models, 0...5 Vdc, 1...5 Vdc, 0...10 Vdc voltage outputs can be provided. (**) Out-of-standard measuring ranges have to be requested when ordering or have to be re-programmed with a Pt100 simulator. (***) Use shielded cables.					

ORDERING CODES

HD9008TRR: Configurable meteorological **temperature and relative humidity** transmitter.

Measuring range -40...+80 °C / 0...100 % R.H. **Two 4...20 mA outputs** (T and R.H.). Probe Ø 26 mm, L = 185 mm. **Power supply 10...30 Vdc.**

HD9008T7S: Meteorological **temperature** transmitter. It measures the temperature with Pt100 1/3 DIN sensor.

Measuring range -40...+80 °C. **RS485 MODBUS-RTU output.** Probe Ø 26 mm, L = 185 mm. **Power supply 5...30 Vdc.**

HD9008T7AC: Meteorological **temperature** transmitter. It measures the temperature with Pt100 1/3 DIN sensor.

Measuring range -40...+80 °C. **4...20 mA output.** Probe Ø 26 mm, L = 185 mm. **Power supply 10...30 Vdc.**

HD9009TRR: Configurable meteorological **temperature and relative humidity** transmitter.

Measuring range -40...+80°C / 0...100 % R.H. **Two 0...1 Vdc outputs** (T and R.H.). Probe Ø 26 mm, L = 185 mm. **Power supply 5...35 Vdc, 2 mA.**

HD9007A-1: 12-ring protection L=190 mm complete with mounting bracket

HD9007A-2: 16-ring protection L=240 mm complete with mounting bracket

HD75: saturated salt solution 75% RH with adapter M 24x1,5

HD33: saturated salt solution 33% RH with adapter M 24x1,5

HD9008.21.1: holder for vertical sensor. Wall distance 250 mm, hole Ø26 mm

HD9008.21.2: holder for vertical sensor. Wall distance 125 mm, hole Ø26 mm.

HD9007 - MULTIPLE RADIATION SHIELD

Characteristics:

Antistatic UV-resistant thermoplastic material with low thermal conductivity and high reflection.

White powder-painted, anticorodal aluminium support bracket. Stainless steel U-bar mounting bracket for shafts from 25 to 44mm.

Dimensions: external Ø 124 mm.

Height, excluding bracket: HD9007A-1: 190 mm, weight 640 gr.

HD9007A-2: 240 mm, weight 760 gr.

Sensor fixing ring nuts: Ø 25 mm ÷ Ø 27 mm.

HD9007 ring-shield is suitable to protect temperature and RH/temperature sensors used in weather stations from solar radiations, rain and wind.

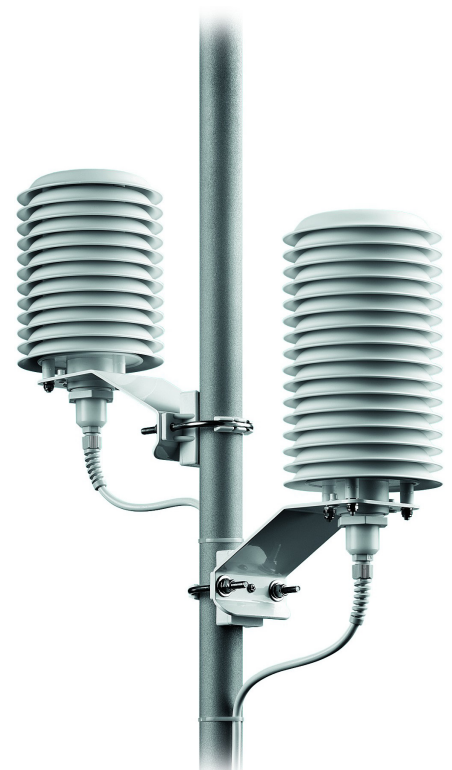
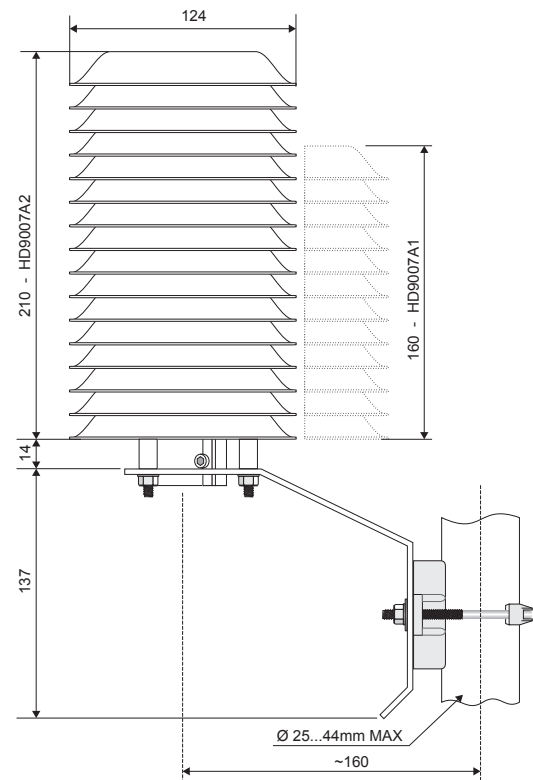

WARRANTY

The manufacturer is required to respond to the “factory warranty” only in those cases provided by Legislative Decree 6 September 2005 - n. 206. Each instrument is sold after rigorous inspections; if any manufacturing defect is found, it is necessary to contact the distributor where the instrument was purchased from. During the warranty period (24 months from the date of invoice) any manufacturing defects found will be repaired free of charge. Misuse, wear, neglect, lack or inefficient maintenance as well as theft and damage during transport are excluded. Warranty does not apply if changes, tampering or unauthorized repairs are made on the product. Solutions, probes, electrodes and microphones are not guaranteed as the improper use, even for a few minutes, may cause irreparable damages. The manufacturer repairs the products that show defects of construction in accordance with the terms and conditions of warranty included in the manual of the product. For any dispute, the competent court is the Court of Padua. The Italian law and the “Convention on Contracts for the International Sales of Goods” apply

TECHNICAL INFORMATION

The quality level of our instruments is the result of the continuous product development. This may lead to differences between the information reported in the manual and the instrument you have purchased. We reserves the right to change technical specifications and dimensions to fit the product requirements without prior notice.

DISPOSAL INFORMATION



Electrical and electronic equipment marked with specific symbol in compliance with 2012/19/EU Directive must be disposed of separately from household waste. European users can hand them over to the dealer or to the manufacturer when purchasing a new electrical and electronic equipment, or to a WEEE collection point designated by local authorities. Illegal disposal is punished by law.

Disposing of electrical and electronic equipment separately from normal waste helps to preserve natural resources and allows materials to be recycled in an environmentally friendly way without risks to human health.

