

## HD2001... series



### HD2001.1 - HD2001.2

## RELATIVE HUMIDITY, TEMPERATURE, BAROMETRIC PRESSURE AND AIR SPEED TRANSMITTERS WITH DISPLAY

The devices of the HD2001 series..., according to the models, measure temperature, relative humidity, barometric pressure and air speed by hot-wire probes.

All models are provided with RS232C or RS485 serial output and the management of more than one device connected to a network. In addition, all the models are fitted with an open collector type low-activated configurable alarm output.

The HD2001.1 model has three configurable analog outputs: 4...20 mA or 0...20 mA current output, 0...10 Vdc or 2...10 Vdc. The choice of output type is made by means of the jumpers set on the board.

Wind speed measurement is detected by the HD2001.2 model with a hot-wire probe set on the upper part of the instrument.

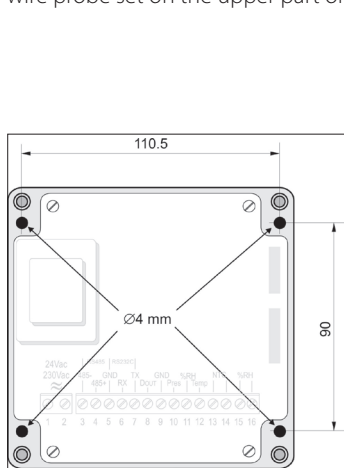

Position of the fixing holes

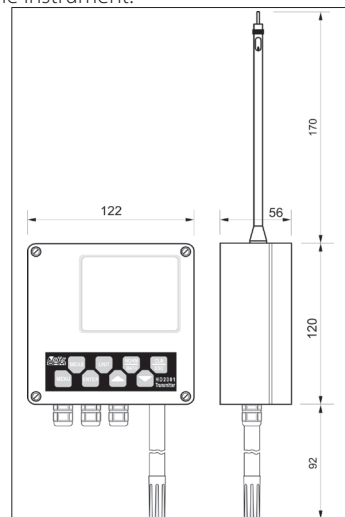

The large display with dual indication on all models allows one of the process variables on the first line and the temperature on the second line, to be displayed.

Following table shows the main characteristics of the models.

Model	Input			Output	
	Temperature % RH	Pressure	Air speed	RS232-RS485 Open collector output	Analog outputs 0...20 mA, 4...20 mA, 0...10 Vdc
HD2001.1	*	*	---	*	*
HD2001.2	*	*	*	*	---

### Technical Specifications (@ 24 Vac and 25 °C)

		HD2001.1	HD2001.2
<b>Inputs</b>			
Temperature	Sensor	NTC 10kΩ	
	Measuring range	-20...+80 °C	
	Accuracy	±0.3 °C in the range 0...+70 °C ±0.4 °C elsewhere	
Humidity	%RH measuring range	0...100 %RH	
	TD measuring range	-20...+80 °C	
	Accuracy	±1.5 %RH (0...90% RH), ±2 %RH (elsewhere) For T=15...35 °C ±(1.5+1.5% of the measure)%RH in the remaining temperature range	
Pressure	Measuring range	600...1100 mbar - 600...1100 hPa - 60...110 kPa	
	Accuracy	±0.5 mbar @25 °C	
	Temperature drift	<1%f.s. (zero); < 1%f.s. (span); From -20°C to +80 °C	
	Long-term stability	<1 mbar/year at 20 °C	
	Fluid contacting the membrane	Air – Non corrosive gas - <b>No liquids</b>	
Wind speed	Type of sensor	---	Hot-wire
	Measuring range	---	0...5 m/s
	Accuracy	---	±0.15 m/s @25 °C
<b>Outputs</b>			
Communications	Type	RS232C and Multidrop RS485	
	Maximum Baud Rate	9600 baud	
Alarm	Type of output	Open collector (low-activated)	
	Maximum voltage	30 Vdc	
	Maximum power	200mW	
Variables		Temperature, %RH, dew point TD, barometric pressure, pressure drop.	Temperature, %RH, dew point TD, barometric pressure, pressure drop and wind speed
Analog	Type of outputs	4...20 mA 0...20 mA 0...10 Vdc 2...10 Vdc	---
	Load resistance	Current output: 500Ω max Voltage output: 100kΩ min	---
	Resolution	16 bit	
Power		24 Vac ±10% 50...60Hz (230 Vac ±10% on request)	
Software		DeltaMet8	
Environmental conditions	Temperature range	-20...+80 °C	
	Humidity range	0...90 %RH - (without condensation)	
	Protection degree	Electronic IP67	

## Display and symbols description

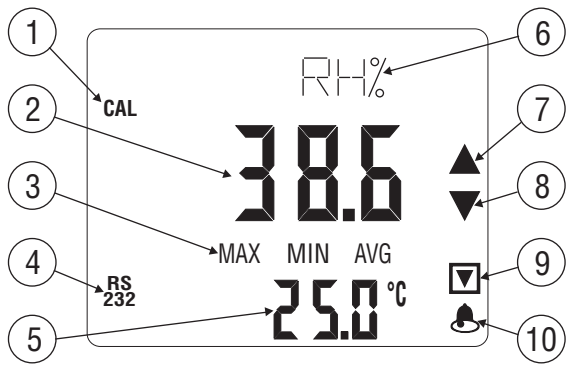

The display constantly shows the measurements of two values.  
Description of the numbers mentioned in the figures:

- CAL**: turns on during calibration of the RH sensor (see the paragraph on calibration).
- Value selectable through the MEAS button. During measurement, this line displays the unit of measurement of the main variable. Inside the menu, it provides information about the active item.
- MAX - MIN - AVG**: indicate that the main measurement reached the maximum (MAX), minimum (MIN) or average (AVG) value since last reset (see the function of the NORM/MATH button).
- RS232**: is turned on when the instrument is connected to a PC.
- Line showing the value of temperature
- Indication of the measurement unit
- and 8. Arrows are lit when the pressure measured by the barometric sensor differs at least 1 mbar from the one measured 6 hours before.
- Indication of pressure drop alarm. It lights up when a pressure drop greater than or equal to the BAR DROP value set in the menu in the range 1...9 mbar has occurred in the last 6 hours.
- It lights up when any of the alarms is exceeded (see paragraph 'Programming the alarms')

## Keyboard description



**MEAS** - by repeatedly pressing this button the main variable displayed in the first line of the display can be selected. This function is cyclic: %RH >> Barometric Pressure >> Wind speed (for the HD2001.2 model) >> %RH... The temperature measured is always visible in the second line of the display.

**UNIT** - this button selects the unit of measurement or the secondary variable correlated to the main variable displayed in the first line of the display.

*Humidity: %RH (relative humidity %) >> g/m<sup>3</sup> (absolute humidity) >> g/kg (mixing ratio) >> Tdew (Dew Point temperature in °C or °F).*  
*Pressure: hPa >> kPa >> mbar.*  
*Wind speed: m/s >> ft/min.*

**NORM/MATH** - it provides the chance to display the maximum (MAX), average (AVG) and minimum (MIN) value for all calculated variables from the moment the MATH button is pressed. This function memorizes the values of the previous measuring session and treats them as initial values for the new calculations. Press the CLEAR/ESC button to reset the memory.  
**CLR/ESC** - it resets the initial values during measurement of the maximum, average, minimum value. Within the menu, it allows to exit the current function without saving the changes.

**ENTER** - within the menu, it confirms the current selection and returns to the measurement. To confirm a parameter without exiting the menu, it is sufficient to display it and proceed with the MENU key  
**UP** - within the menu, it increases the current value.  
**DOWN** - within the menu, it decreases the current value.  
**MENU** - This key is used to access the instrument menu: the individual items are described in the upper part of the display by flowing text. To modify an individual item, use the arrows; to confirm it and remain in the menu, press the MENU button; to confirm it and return to measurement, press the ENTER button.

**NOTE: For clarification, terms appearing on the display are indicated, in the explanation below, in bold capital letters (e.g. TEMP stands for temperature, CEN stands for Centigrade).**

- TEMPerature CENTigrade or FAHRenheit**: selection of the unit of measurement for the temperature between Centigrade or Fahrenheit.
- BAUD RATE**: Selection of the data transmission speed for data communication using the RS232C or RS485 serial port. Various values are available: 300, 1200, 2400, 4800 and 9600. We recommend using the maximum speed of 9600 baud.
- PRINT AUTO**: 1 = YES, 0 = NO. Enables (= 1) or disables (= 0) the continuous data transmission on the serial port (continuous printing) according to a frequency equal to the interval set in the item **INTV SEC**. Date, time, temperature, relative humidity, absolute humidity, mixing ratio, dew point, barometric pressure, wind speed (in m/s or in ft/min) are printed. The units of measurement are the same as those used on the display.
- INTerVal SECONDS**. Print interval in seconds.
- YEAR**: menu item to set the year. The date is kept until the instrument is on. If the instrument is turned off when not connected to a PC, the date must be reset from the keyboard. If it is connected to a PC and a power failure occurs, when reconnecting the power the PC automatically updates the instrument date without needing to use the keyboard.
- MONth**: Current month.
- DAY**: Current day.
- HOUR**: Current hour.
- ESC ZEROs SECONDS, MINutes**: current minutes. The seconds can be reset by pressing ESC. In order to set the hour precisely, simply set it one minute in advance and when the new minute strikes, press ESC. For example, if it is 11:20.10 and you wish to correct the time, set it to HOUR=11, MIN=21 and when the new minute strikes (21), press ESC: thus the time is synchronized to the second at 11:21.00.
- NUMBER INSTRUMENT ADDRESS**: it sets the identification (ID) of the instrument to be able to use it within a network. The numbers from 0 (first instrument) to 255 are available. For the details see the paragraph dealing with serial communication.



HD2001.1: temperature, humidity, pressure, serial and analogue output.

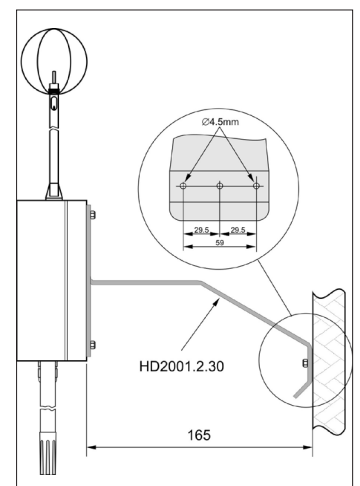

Support for model HD2001.2

11. **SET ALARM 1** = YES, 0 = NO: Enables (=1) or disables (=0) the open collector low-activated alarm output. The settings submenu can be entered using the upward arrow (UP). For the details see the paragraph on alarm programming.
12. **ENABLE CALibration**: Enables the calibration of the relative humidity sensor. For the details see the paragraph on calibration.

## Installation and connections

The instrument is set up to work indoors, four holes are present to fix the container. The pressure and humidity sensors are set downwards so that the accumulation of dust and dirt is reduced to the minimum.

### Model HD2001.2

The HD2001.2 model is fitted with an omnidirectional hot-wire probe: the sensor set on the top of the probe is very delicate and must be protected with the special frame provided with the instrument. During transportation, the sensor is closed into a cylinder screwed on the end part of the probe: during installation, unscrew this cylinder and screw the protection frame in its place.

In order to measure the wind speed accurately, the instrument must be set at a certain distance from the wall using the HD2001.2.30 pole, as indicated in the figure in the previous page.

### Serial communication and instruments' network

The instrument is fitted with RS232C and Multidrop RS485 serial ports for connection to a PC. Thanks to the RS485 protocol it is possible to connect more than one instrument to form a network managed by the DeltaMet8 software downloadable from the website.

The protocol is selected by using dip-switch N. 1 set on the display board. When only one instrument is used, set at a maximum distance of 15 m from the PC, use the RS232C serial connection. To cover longer distances (until 1200 m) or to create a network of instruments, the RS485 port must be used with a special RS232/RS485 or USB/RS485 converter.

A network is formed by a maximum of 256 devices tandem-connected through a shielded twisted pair cable. The first element of the network connected to the PC may use the RS232C protocol and can be an interface between the PC and the rest of the network: so using an RS232C/RS485 converter can be avoided (*only if the first instrument is less than 15 m away from the PC*).

In order that communication along the network work correctly, each instrument needs to be identified by an ID number differing from all the others. On the first start up, after commuting the protocol selection dip-switch, the ID of the instrument is automatically set to "0" if the RS232C protocol is selected, and set to "1" if the RS485 protocol is selected: using the menu item "**NUMBER INSTRUMENT ADDRESS**" these IDs can be changed and memorized in order to set up new components on the network. To maximally speed up the data transmission, we recommend using the highest baud rate available of 9600 baud: you should only reduce this value when communication problems occur.

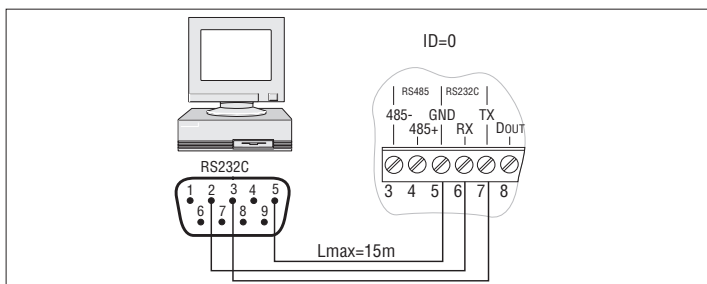

Connection to PC/ device with RS232C protocol.

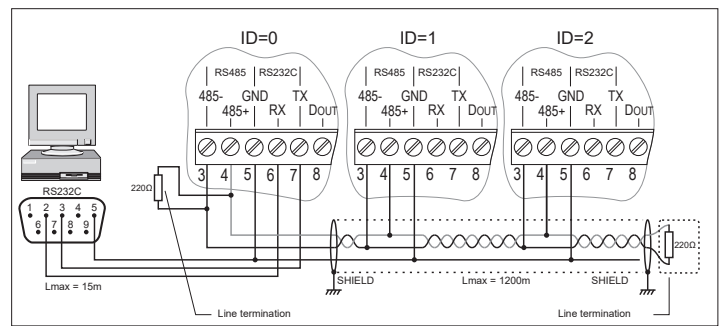

RS485 network in which the conversion function is performed by first instrument of the network. The instrument that is connected directly to PC is identified by the ID = 0 and must be placed no more than 15 m away from the PC. If your PC does not have the RS232C connection, you must insert a USB/RS232C converter between the PC and the first instrument of the network.

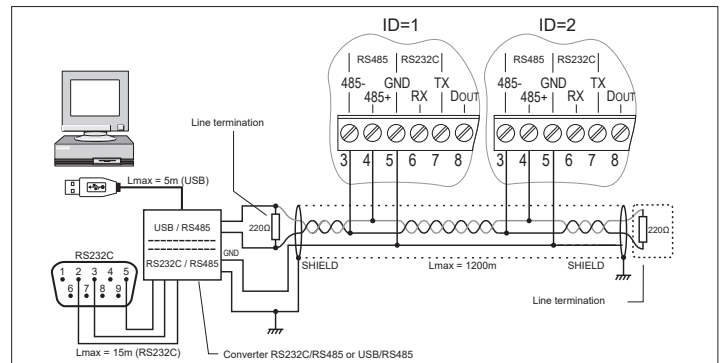

PC Connection with the RS485 communication protocol for distances up to 1200 m. The instruments are tandem-connected through a shielded twisted pair cable for signals and a third wire for grounding. Both ends of the network need to have resistors for impedance matching (Line terminations). To polarize the line during periods of non-transmission, resistors connected between the signal and the power line have to be used. For PC connection it is necessary to use a RS232/485 or USB/RS485 converter.

### Programming the alarms

Each model is fitted with an open collector low-activated alarm output. This output commutes when enabled if any of the limits, associated with the measurement variables of all the instrument's values, exceeds the maximum level or goes below the minimum level. The activation and deactivation of the alarm effects only the physical output and not the display indication which in contrast always remains enabled. **To avoid one of the variables intervening, simply set the limits to the extreme working limits of the measurement range.** Except for pressure drop, for each physical quantity, a lower level (LOW) and an upper level (HIGH) must be entered with LOW lower than HIGH.

### Setting

Browse the menu items until the item SET ALARM 1 = YES, 0 = NO: press the up arrow (UP) to access the setting of the limits. The writing changes and becomes **ReLAY ALARM ENaBled** (Alarm output enabled): to enable the output maintaining the previous settings, press ENTER. To activate the output and change settings, press the MENU button: then the lower (LOW) and upper (HIGH) alarm limits for each available physical value will be displayed.

For example, "**SET TEMPerature LOW**" sets the minimum alarm limit of the temperature; using the arrows enter the desired value and then proceed with the MENU button to modify the other parameters. Pressing ESC, the current parameter on display is reset to the initial value.

The variables are listed in this order: temperature, relative humidity, dew point, barometric pressure, pressure drop (DROP) in the last 6 hours and, for the HD2001.2 model, wind speed.

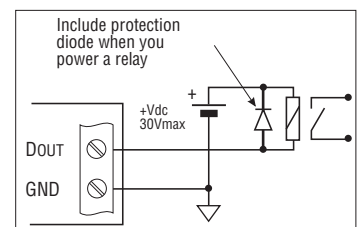

Typical connection for alarm relay activation

## Current and voltage analog outputs for the HD2001.1 models

The models are provided with current or voltage analog outputs, one for each value, each associated with a physical value measured by the instrument. The available outputs are 0...20 mA, 4...20 mA, 0...10 Vdc or 2...10 Vdc. The relation between output range (current and voltage) and input range is fixed: the output minimum and maximum values are associated with the minimum and maximum values of the input variables.

HD2001.1 - Inputs / analog outputs ratio	
Inputs	Analog outputs
-20 ... +80 °C	4...20 mA
0...100 %RH	0...20 mA
600...1100 mbar	0...10 Vdc
	2...10 Vdc

The type of output is selected using dip-switch N. 2 set on the display card and the jumpers set near the analog output terminals (see fig. below): the various combination are outlined in the following table in which the relevant output is reported according to the position of the switches.

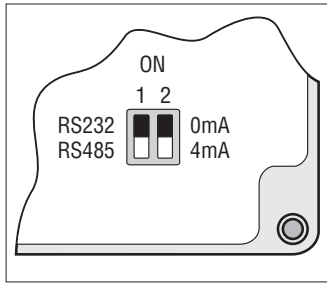

Selection dip switch for protocol RS232/RS485 and analogue output.

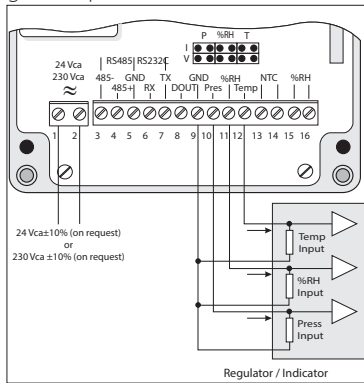

Connection example of the analogue output to an indicator/regulator.

Dip-switch no. 2	0 mA	0 mA	4 mA	4 mA
Position of the jumper	I	V	I	V
Output selected	0...20 mA	0...10 Vdc	4...20 mA	2...10 Vdc

The output range is determined for both output types by the dip-switch no. 2 setting. For example the outputs 0...20 mA and 0...10 Vdc or 4...20 mA and 2...10 Vdc can coexist, but for example, the outputs 0...20 mA and 4...20 mA cannot coexist. For correct functioning, we recommend observing the load specifications concerning the analog outputs reported in the technical information.

## Calibration of the relative humidity sensor HD2001.1

For a correct calibration on the relative humidity sensor, it is fundamental to know and abide by the physical phenomena on which the measurement is based: for this reason, it is advisable to carefully assess the need for recalibration before and, if a recalibration is carried out, it is recommended to strictly follow the below

### Calibration of the humidity sensor offset

1. Enter the probe in the container with the saturated solution at 75% relative humidity at about 20 °C. Wait at least 30 minutes.
2. Using the MENU button select the item "ENaBLE CALibration", press the UP arrow until reaching #51: the calibration procedure is started automatically.
3. The display indicates "CAL RH". Using the arrows, adjust the relative humidity value indicated on the display according to the temperature of the calibration salts: the value to be set is shown on the container's label of the saturated salt used.
4. Wait a few minutes to ensure the reading is stable.
5. Press ENTER to confirm this value. The instrument returns to normal measurement.
6. Remove the probe from the container and close it immediately using its lid.

## Calibration of the humidity sensor slope

1. Enter the probe in the container with the saturated solution at 33% of relative humidity. Wait at least 30 minutes.
2. Using the MENU button select the item "ENaBLE CALibration", press the UP arrow until reaching #51: the calibration procedure is started automatically.
3. The display indicates "CAL RH". Using the arrows, adjust the relative humidity value indicated on the display according to the temperature of the calibration salts: the value to be set is shown on the container's label of the saturated salt used.
4. Wait a few minutes to ensure the reading is stable.
5. Press ENTER to confirm this value. The instrument returns to normal measurement.
6. Remove the probe from the container and close it immediately using its lid.

Note: the calibration of the sensor is usually carried out on both points, first at 75 %RH and then at 33 %RH, but it can be carried out on one of the points only, to e.g. regulate a small drift at 75% or 33%. When exiting calibration, the instrument checks whether the procedure has been carried out correctly and signals any faults by flashing the CAL symbol. If the flashing occurs at the end of the calibration of one of the two points, it means that the other point must also be calibrated

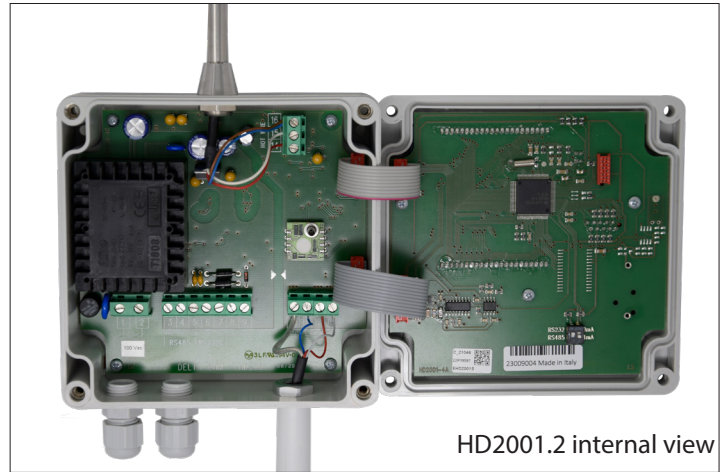

HD2001.2 internal view

## ORDERING CODES

**HD2001.1:** Indicator/transmitter of temperature, relative humidity, barometric pressure with selectable 0...20 mA, 4...20 mA, 0...10 V or 2...10 V outputs. Open collector alarm output and RS232C or RS485 PC connection. DeltaMet8 software for PC connection downloadable from Delta OHM website.

Available models:

- HD2001.1TV1 - vertical probe
- HD2001.1TC... - external probe with cable 2 m (HD2001.1TC1.2); 5 m (HD2001.1TC1.5) or 10 m (HD2001.1TC1.10)

**HD2001.2:** Indicator/transmitter of temperature, relative humidity, barometric pressure and wind speed. Open collector alarm output and RS232C or RS485 PC connection. DeltaMet8 software for PC connection downloadable from Delta OHM website.

**HD2001.2.30:** Wall mounting support for HD2001.2.

**HD75:** Saturated salt solution 75% R.H. Adapter M 12x1.

**HD33:** Saturated salt solution 33% R.H. Adapter M 12x1