

English

Operating manual

Low pressure transmitters
HD404... series



Members of GHM GROUP:

GREISINGER

HONSBERG

Martens

Delta OHM

VAL.CO

www.deltaohm.com

Keep for future reference.

TABLE OF CONTENTS

1	INTRODUCTION	3
2	TECHNICAL CHARACTERISTICS	5
3	INSTALLATION	8
3.1	ELECTRICAL CONNECTIONS	10
3.2	EXAMPLE OF CONNECTION TO A PITOT TUBE.....	11
3.3	EXAMPLES OF CONNECTION WITH HD9022 INDICATOR/REGULATOR	12
4	CONFIGURATION	13
4.1	CONFIGURATION OF THE MODELS WITH ANALOG OUTPUT (HD404T...)	13
4.2	CONFIGURATION OF THE MODELS WITH RS485 OUTPUT (HD404ST...).....	15
4.3	NOTES ON THE CONFIGURATION OF THE MODELS WITH SR OPTION	17
4.4	ERROR MESSAGES ON DISPLAY	17
5	MODBUS-RTU PROTOCOL (HD404ST...)	18
6	INSTRUMENT STORAGE	20
7	SAFETY INSTRUCTION.....	20
8	ACCESSORIES ORDERING CODES	21

1 INTRODUCTION

The series of **HD404...** transmitters is able to measure relative pressures with reference to the atmosphere or differential in the range:

- from 50 to 1000 Pa (from 0.2" H₂O to 4" H₂O) for the versions with analog output;
- 250 Pa / 1000 Pa / 100 mbar for the versions with RS485 Modbus RTU output.

The transmitters use a "micromachined" temperature compensated silicon sensor that has an excellent linearity, repeatability and stability over time.

The sensor signal is amplified and converted, depending on the model, into a standard current (4-20 mA) or voltage (0-10 V) analog output, or into a digital RS485 Modbus RTU output, and can therefore be transmitted over long distances with a high noise immunity.

In the models with analog output it is possible to choose, via a dip switch, between two measurement ranges in order to select the optimal scale for each application.

An optional auto-zero circuit (**AZ**) periodically equalizes the differential pressure at the sensor input and corrects the offset; the transmitters equipped with this circuit are insensitive to the mounting position. In addition, the auto zero circuit compensates the sensor aging and deviation of the zero with temperature changes, eliminating the maintenance.

The display option (**L**) is available, in which the pressure is visualized on a 4-digit display in the chosen measurement unit.

The "square root" version (**SR**) is especially useful if the transmitter is connected to a Pitot or Darcy tube, as the output is directly proportional to the speed of airflow. The SR version with L option also allows displaying, in addition to the pressure measured, the calculated airflow speed. It is possible to set the coefficient of the Pitot or Darcy tube used and the parameters for the calculation of the speed (air flow temperature, barometric pressure, differential static pressure in the duct). In the models with analog output it is possible to set the full scale speed for the output.

The instruments are factory calibrated and ready for use.

Models with analog output

HD404T

				<p>"" = pressure output SR = speed output (only G versions)</p>												
				<p>"" = without LCD L = with LCD</p>												
				<p>"" = without auto-zero circuit (only HD404T3... and HD404T4...) AZ = with auto-zero circuit</p>												
				<p>D = differential pressure -f.s....+f.s. G = relative pressure with respect to the atmosphere 0...+f.s.</p>												
<p>Nominal full scale (f.s.)</p> <table border="0"> <tr> <td>1P = 100 Pa</td> <td>1M = 10 mmH₂O</td> <td>1I = 0.4" H₂O</td> </tr> <tr> <td>2P = 250 Pa</td> <td>2M = 25 mmH₂O</td> <td>2I = 0.8" H₂O</td> </tr> <tr> <td>3P = 500 Pa</td> <td>3M = 50 mmH₂O</td> <td>3I = 2" H₂O</td> </tr> <tr> <td>4P = 1000 Pa</td> <td>4M = 100 mmH₂O</td> <td>4I = 4" H₂O</td> </tr> </table>					1P = 100 Pa	1M = 10 mmH ₂ O	1I = 0.4" H ₂ O	2P = 250 Pa	2M = 25 mmH ₂ O	2I = 0.8" H ₂ O	3P = 500 Pa	3M = 50 mmH ₂ O	3I = 2" H ₂ O	4P = 1000 Pa	4M = 100 mmH ₂ O	4I = 4" H ₂ O
1P = 100 Pa	1M = 10 mmH ₂ O	1I = 0.4" H ₂ O														
2P = 250 Pa	2M = 25 mmH ₂ O	2I = 0.8" H ₂ O														
3P = 500 Pa	3M = 50 mmH ₂ O	3I = 2" H ₂ O														
4P = 1000 Pa	4M = 100 mmH ₂ O	4I = 4" H ₂ O														

Models with RS485 Modbus-RTU output

HD404ST

			<p>"" = pressure output SR = speed output</p>
			<p>"" = without LCD L = with LCD</p>
			<p>"" = without auto-zero circuit (only HD404ST4... and HD404ST5...) AZ = with auto-zero circuit</p>
<p>Nominal full scale (f.s.)</p> <p>2 = -250 ... +250 Pa 4 = -1000 ... +1000 Pa 5 = -100 ... +100 mbar</p>			

2 TECHNICAL CHARACTERISTICS

Sensor	Piezoresistive
Measuring range	See tables 2.1 and 2.2
Resolution	0.1 Pa for HD404ST2... 0.5 Pa for f.s. up to 500 Pa (except Hd404ST2...) 1 Pa for f.s. 1000 Pa 0.1 mbar for HD404ST5... 0.05 mmH ₂ O for f.s. up to 50 mmH ₂ O 0.1 mmH ₂ O for f.s. 100 mmH ₂ O 0.002" H ₂ O for f.s. up to 4" H ₂ O 0.01 m/s (only SR versions)
Accuracy	See table 2.1
Long-term stability	See table 2.1
Output	<ul style="list-style-type: none"> • HD404T...: Active analog 0...10 Vdc ($R_{Lmin} = 10\text{ k}\Omega$) or 4...20 mA ($R_{Lmax} = 500\ \Omega$) • HD404ST...: Digital RS485 Modbus-RTU
Response time	<ul style="list-style-type: none"> • HD404T... with dip-switch set to FAST: 0.125 s in pressure mode 1 s in speed mode (only SR versions) • HD404T... with dip-switch set to LOW: Configurable 1, 2 or 4 s (default 2 s) • HD404ST...: Configurable 0.125, 1, 2 or 4 s (default 2 s)
Overpressure limit	50 kPa
Connection to PC	<ul style="list-style-type: none"> • HD404T...: RS232 serial port Can be connect to a USB port by using the optional CP27 adapter • HD404ST...: Can be connect to a USB port by using the optional RS48 adapter
Zero calibration	Automatic for the versions with AZ option
Compatible media	Only air and non-aggressive dry gases
Power supply	<ul style="list-style-type: none"> • HD404T...: 24 Vac \pm 10% o 18...40 Vdc • HD404ST...: 12...30 Vdc
Absorption	<ul style="list-style-type: none"> • HD404T...: < 1 W @ 24 Vdc • HD404ST...: < 100 mW @ 12 Vdc
Pressure connection	Nickel-plated brass, \varnothing 6 mm
Electrical connections	Screw terminal block, max 1.5 mm ² , PG9 cable gland
Operating conditions	-10...+60 °C (-5...+50 °C for the models with AZ option), 0...95% RH
Storage temperature	-20...+70 °C
Housing dimensions	80 x 84 x 44 mm
Protection degree	IP65

TAB. 2.1: pressure measuring ranges, accuracy and long term stability

MODEL	MEASURING RANGE		ACCURACY ⁽¹⁾ (@ 0...+50 °C)		LONG-TERM STABILITY ⁽²⁾	
	LOW	HIGH	AZ	NO AZ	AZ	NO AZ
MODELS WITH ANALOG OUTPUT (HD404T...)						
Pa (HD404TxP...)						
HD404T1PGAZ...	0...50	0...100	±(0.8% measure + 0.5)	-	≤±0.2	-
HD404T2PGAZ...	0...100	0...250		-		
HD404T3PG...	0...250	0...500		±1% f.s. nom.		≤±8
HD404T4PG...	0...500	0...1000		-		-
HD404T1PDAZ...	±50	±100		-		-
HD404T2PDAZ...	±100	±250		-		-
HD404T3PD...	±250	±500		±1% f.s. nom.		≤±8
HD404T4PD...	±500	±1000		-		-
mmH₂O (HD404TxM...)						
HD404T1MGAZ...	0...5	0...10	±(0.8% measure + 0.05)	-	≤±0.02	-
HD404T2MGAZ...	0...10	0...25		-		
HD404T3MG...	0...25	0...50		±1% f.s. nom.		≤±0.8
HD404T4MG...	0...50	0...100		-		-
HD404T1MDAZ...	±5	±10		-		-
HD404T2MDAZ...	±10	±25		-		-
HD404T3MD...	±25	±50		±1% f.s. nom.		≤±0.8
HD404T4MD...	±50	±100		-		-
inchH₂O (HD404TxI...)						
HD404T1IGAZ...	0...0.2	0...0.4	±(0.8% measure + 0.002)	-	≤±0.0008	-
HD404T2IGAZ...	0...0.4	0...1		-		
HD404T3IG...	0...1	0...2		±1% f.s. nom.		≤±0.04
HD404T4IG...	0...2	0...4		-		-
HD404T1IDAZ...	±0.2	±0.4		-		-
HD404T2IDAZ...	±0.4	±1		-		-
HD404T3ID...	±1	±2		±1% f.s. nom.		≤±0.04
HD404T4ID...	±2	±4		-		-
MODELS WITH RS485 MODBUS-RTU OUTPUT (HD404ST...)						
HD404ST2AZ...	±250 Pa		±(0.8% measure + 0.5) Pa	-	≤±0.2 Pa	-
HD404ST4...	±1000 Pa			±1% f.s.		≤±8 Pa
HD404ST5...	±100 mbar		±(0.8% measure + 0.005) mbar	±1% f.s.	≤±0.002 mbar	≤±0.08 mbar

(1) f.s. nom. (nominal) = full scale of "HIGH" measuring range.

(2) Long-term stability refers to 1 year.

TAB.2.2: Speed full scale in the models with SR option

MODEL	MAX SPEED MEASURABLE ⁽³⁾ (m/s)		ANALOG OUTPUT DEFAULT FULL SCALE (m/s)
	LOW	HIGH	
HD404TxP...SR			
HD404T1PGAZ...SR	9.06	12.82	10
HD404T2PGAZ...SR	12.82	20.27	20
HD404T3PG...SR	20.27	28.67	25
HD404T4PG...SR	28.67	40.55	40
HD404TxM...SR			
HD404T1MGAZ...SR	8.98	12.70	10
HD404T2MGAZ...SR	12.70	20.08	20
HD404T3MG...SR	20.08	28.39	25
HD404T4MG...SR	28.39	40.16	40
HD404TxI...SR			
HD404T1IGAZ...SR	9.05	12.80	10
HD404T2IGAZ...SR	12.80	20.24	20
HD404T3IG...SR	20.24	28.62	25
HD404T4IG...SR	28.62	40.48	40

⁽³⁾ The maximum speed measurable depends on various parameters. Table 2.2 shows the maximum speed measurable with the factory default values:

- **K = 1.0** → Tube coefficient
- **T = 16.0 °C** → Air flow temperature
- **Patm = 1013.25 mbar** → Barometric pressure
- **Ps = 0** → Differential static pressure, equal to the difference between the absolute static pressure inside the duct and the barometric pressure. Ps is zero if the duct is open (in contact with the atmosphere); Ps can be different from zero if the duct is closed.

In the models HD404T..., the serial command SV provides the maximum speed measurable as a function of the parameters setting, while the command CS allows setting the full scale speed of the analog output.

The following graphs show the change of the maximum measurable speed value (normalized to 1 for T=16.0 °C and Patm=1013.25 mbar) with the change of the temperature and barometric pressure.

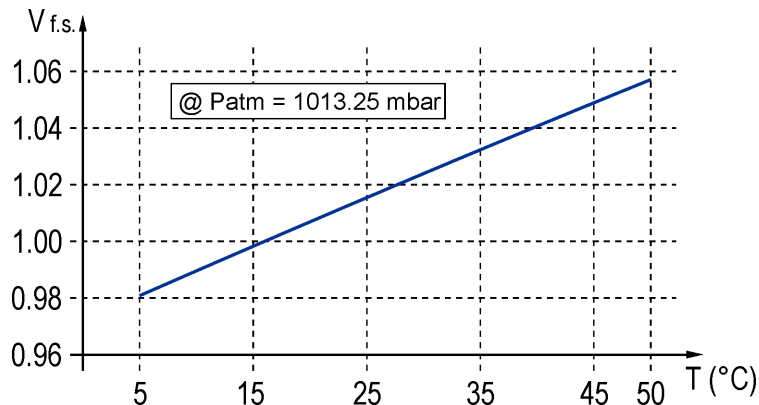

Change of the max. speed with the temperature at constant barometric pressure

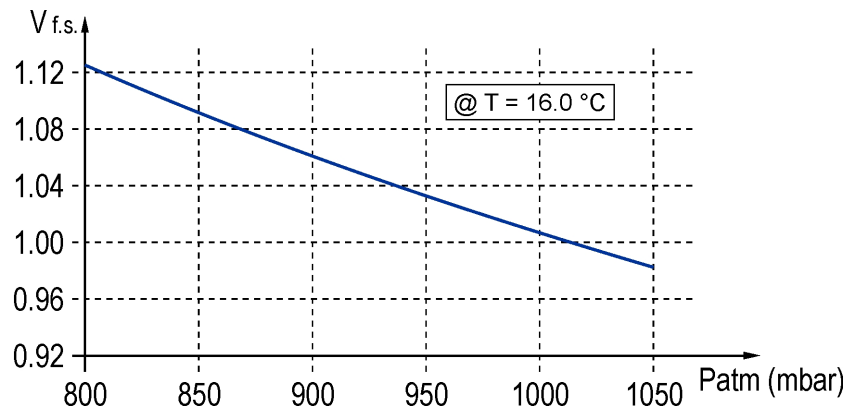

Change of the max. speed with the barometric pressure at constant temperature

DIMENSIONS (mm)

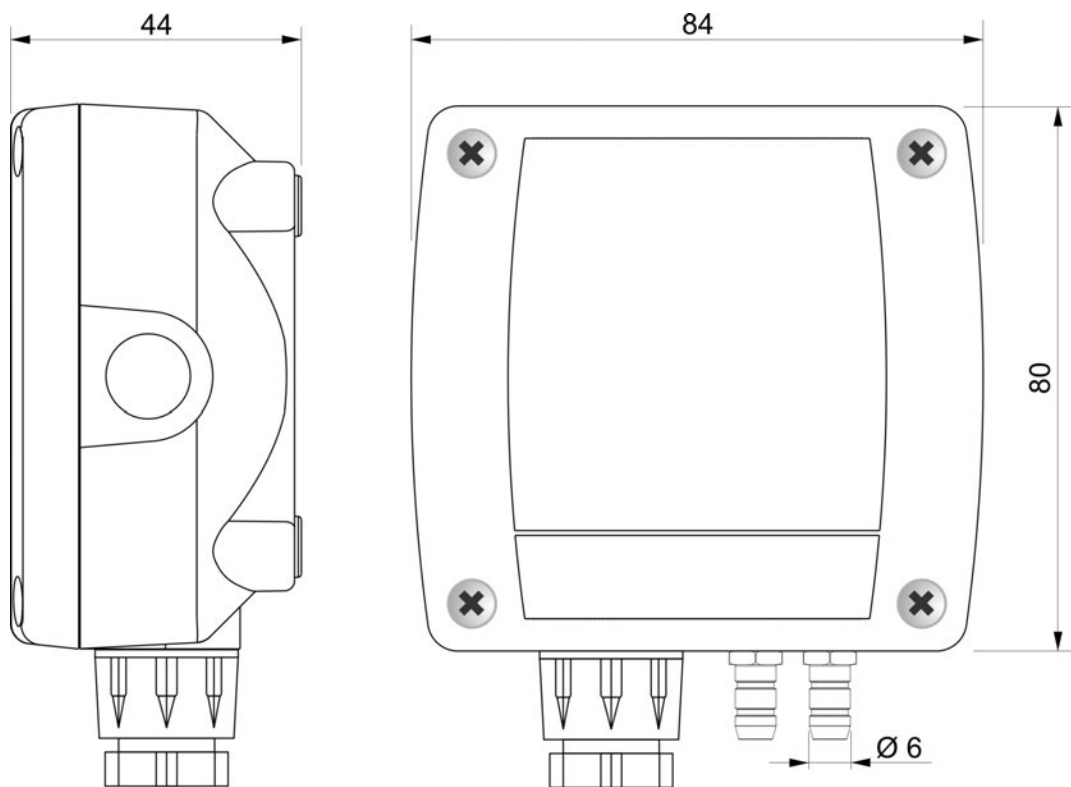

3 INSTALLATION

By opening the lid, 3 mm diameter holes are available so to allow securing the base of the instrument directly to a panel or to the wall.

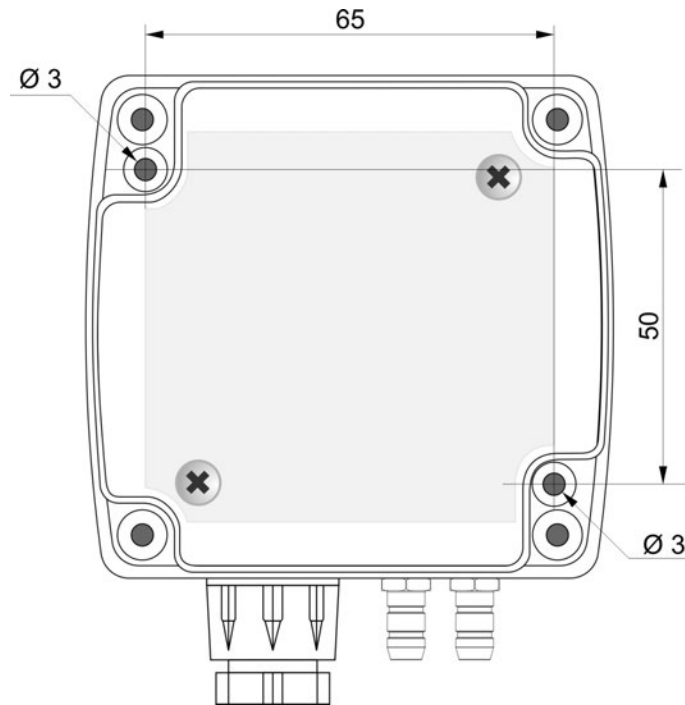

Internally there are:

- the terminal header for connecting the power supply and the output;
- the RS232 serial connector (COM AUX, except HD404ST...);
- the dip switches for quick configuration.
- The CAL ZERO button.

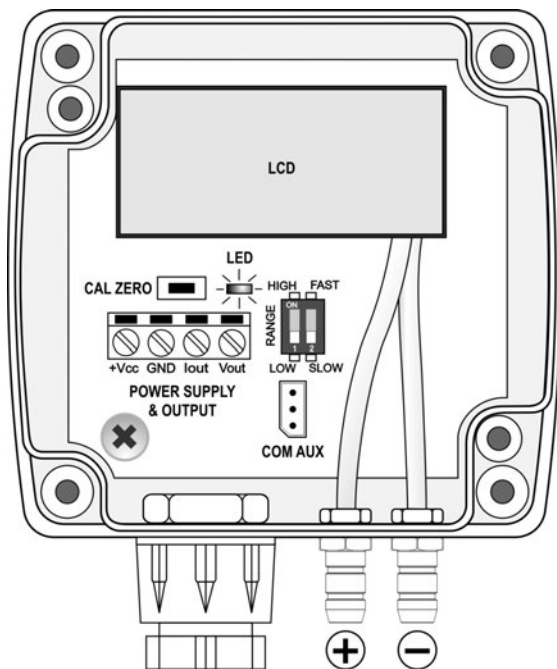

**Models with active analog output
(HD404T...)**

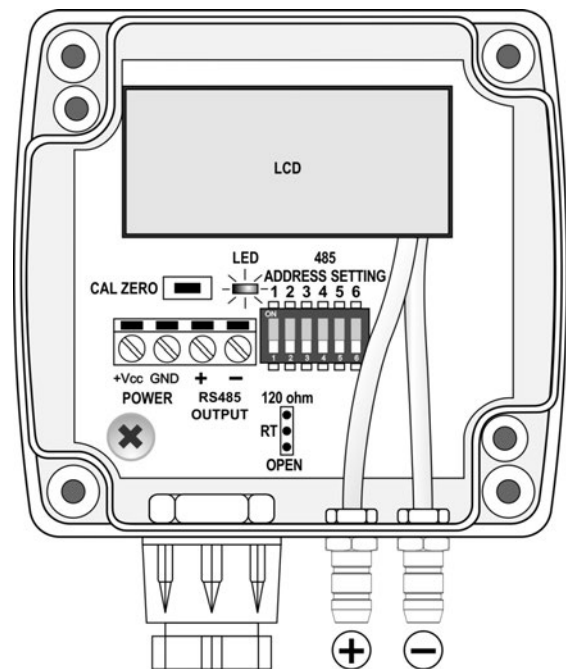

**Models with digital RS485 output
(HD404ST...)**

The instruments can be mounted in any position, but typically they are fixed on a vertical wall with the pressure inputs facing down.

The deviation of the zero due to the mounting position can be corrected by using the CAL ZERO button. In the models with AZ option, an auto-zero circuit periodically automatically equalizes the differential pressure at the input of the sensor and corrects the offset due to the mounting position or sensor aging.

To manually calibrate the zero, disconnect both the tubes from the + and – pressure inputs, then proceed as follows:

- press CAL ZERO until the red LED starts flashing;
- when the red LED turns off, the zeroing procedure is completed: reconnect the tubes to the pressure inputs.

In the models without AZ option, it is recommended to follow the auto zero procedure at least once a year under normal operating conditions.

In models with AZ option, the zeroing is performed hourly. During the zeroing, which takes about 4 seconds, the output and the display remain frozen at the last measured value.

3.1 ELECTRICAL CONNECTIONS

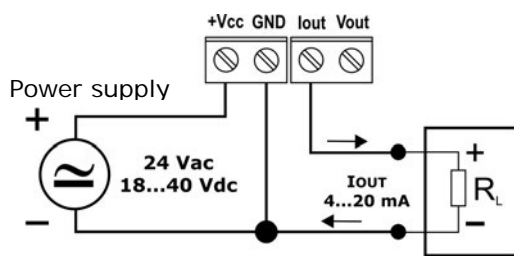

Current analog output

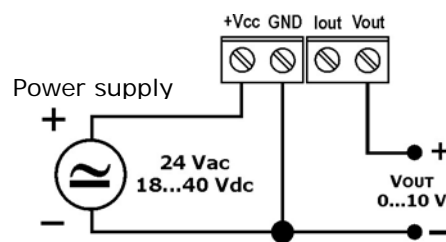

Voltage analog output

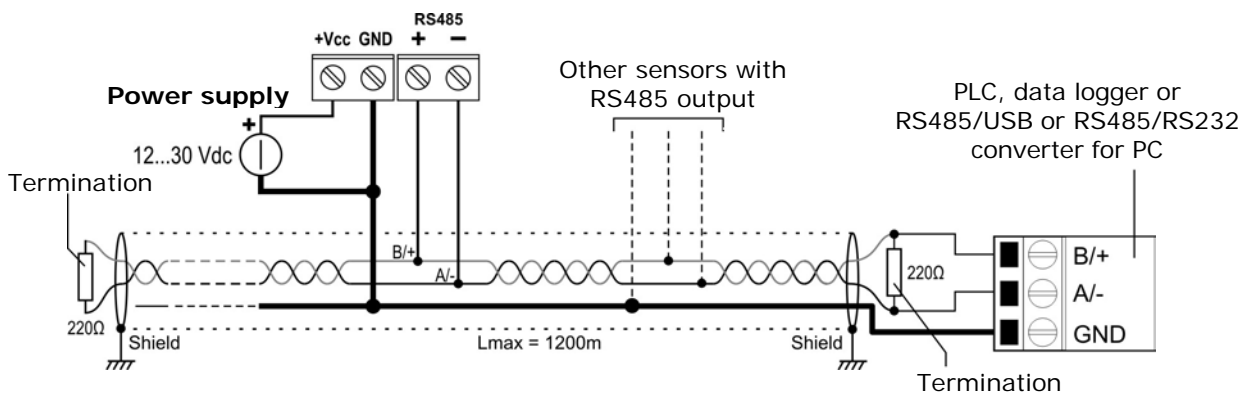

RS485 connection

In the RS485 connection, the instruments are connected in a sequence through a shielded cable with twisted pair for signals and a third wire for the common. Line termination must be set at the two network ends.

The maximum number of devices that can be connected to the RS485 line (Bus) depends on the load characteristics of the devices to be connected. The RS485 standard requires that the total load does not exceed 32 unit loads. The load of an HD404ST... transmitter is equal to ¼ of unit load. If the total load is greater than 32 unit loads,

divide the network into segments and add a signal repeater between a segment and the successive one. Line termination should be applied at both ends of each segment.

The instrument has a built-in line termination that can be connected or removed through a short jumper placed next to the terminal block. If the instrument is the last or the first device of a network group, connect the termination placing the short jumper between the "RT" and "120 ohm" indications. If the instrument is not at the end of a network group, remove the termination placing the short jumper between the "RT" and "OPEN" indications.

The cable shield must be connected to both line ends. The cable should have the following features:

- Characteristic impedance: 120 ohm
- Capacity: less than 50pF/m
- Resistance: less than 100 ohm/km
- Gauge: 0.22 mm² (AWG24) at least

The cable maximum length depends on baud rate and cable characteristics. Typically, the maximum length is 1200 m. The data line must be kept separated from any power lines in order to prevent interferences on the transmitted signal.

3.2 EXAMPLE OF CONNECTION TO A PITOT TUBE

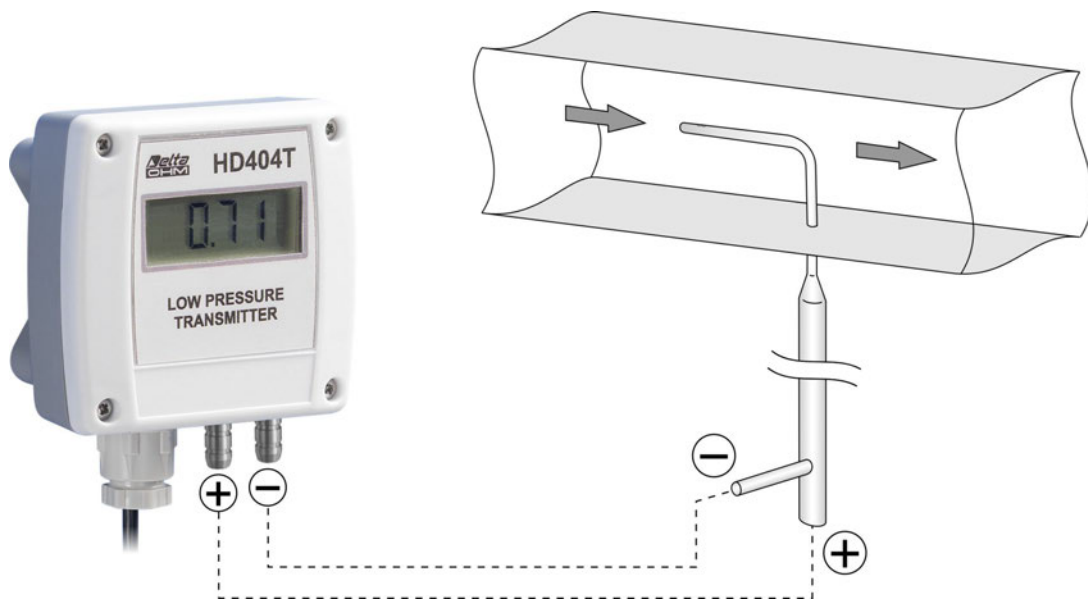

Transmitter with SR option connected to a Pitot tube

3.3 EXAMPLES OF CONNECTION WITH HD9022 INDICATOR/REGULATOR

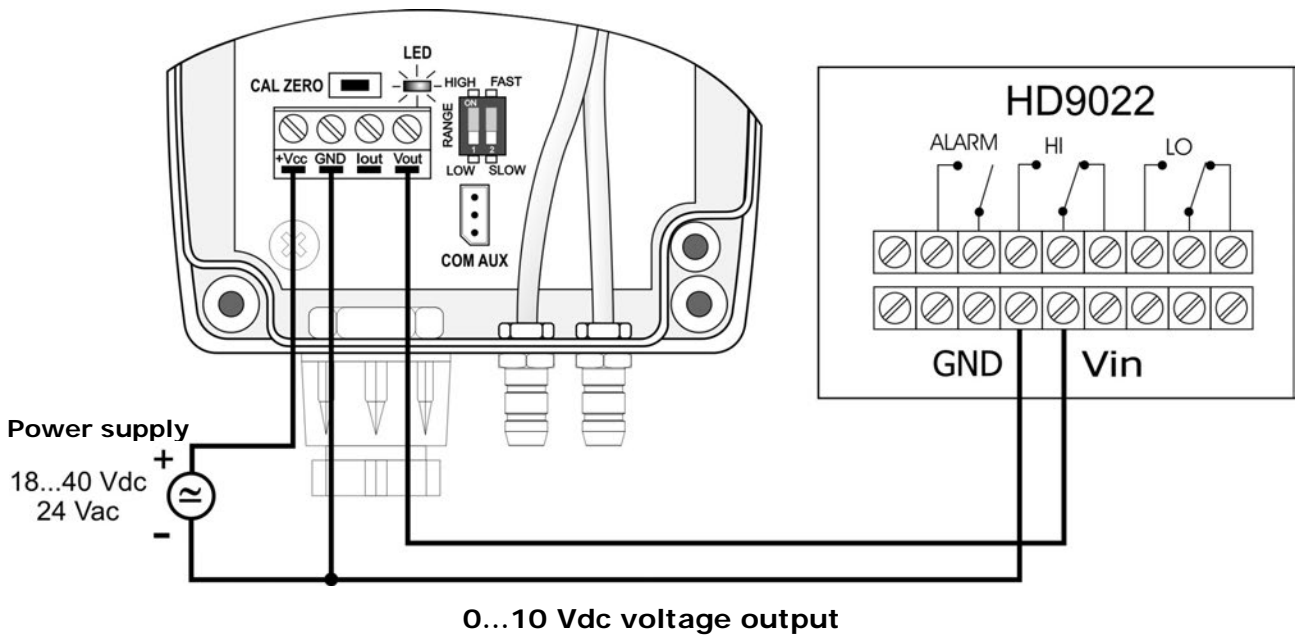
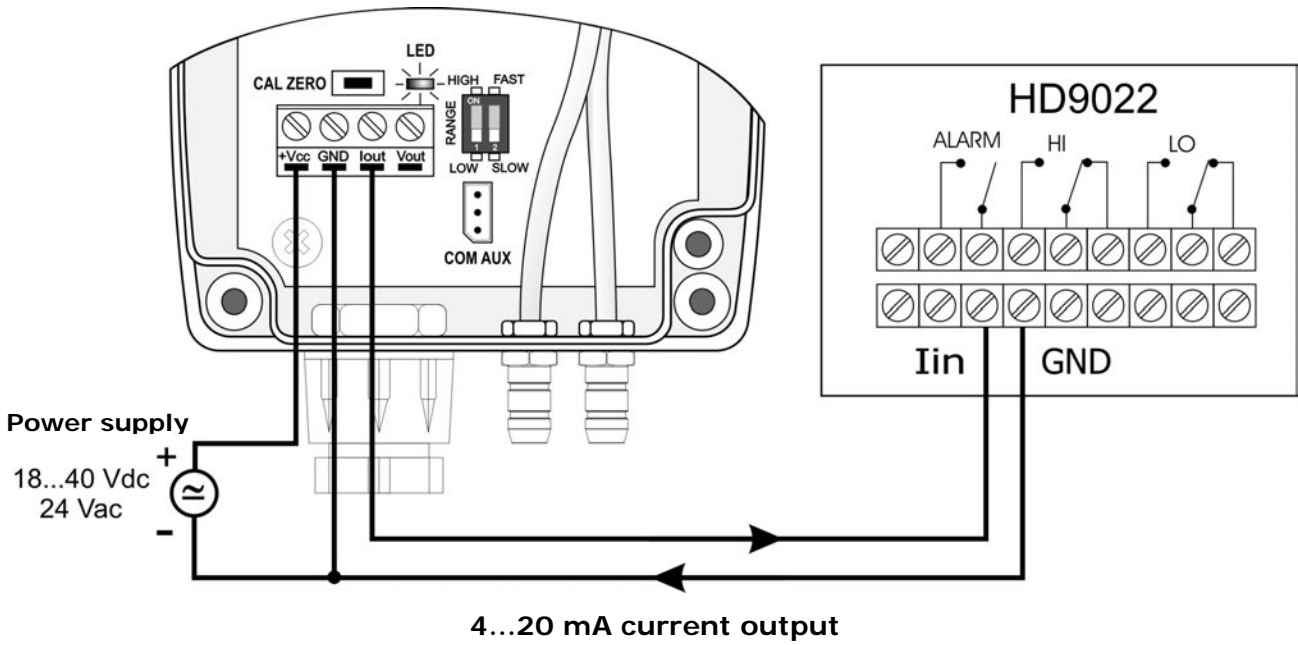

4 CONFIGURATION

4.1 CONFIGURATION OF THE MODELS WITH ANALOG OUTPUT (HD404T...)

The transmitter can be configured by using the **dip switches** on the circuit board and via the serial communication port **COM AUX**.

Configuration via dip switches:

Dip switches **RANGE**: selection of the LOW or HIGH range for the analog output.

Dip switches **FAST/SLOW**: selection of the response time for the analog output. In FAST mode the response time is 0.125 s in pressure measurement mode and about 1 s in speed measurement mode, while in SLOW mode the response time is selectable to 1, 2 or 4 s by means of the S1, S2 or S4 serial commands respectively. SLOW mode is recommended if there are conditions of turbulence or disruption of air flow.

Configuration via the serial port COM AUX:

In order to modify the settings, please proceed as follows:

- Connect the serial COM AUX output of the transmitter to the RS232 port (via the RS27 cable) or USB (via the cable CP27) of the PC. If you use the CP27 cable, install the USB drivers on your PC.
- On the PC, run a serial communication software, set the baud rate to 115200 and the communication parameters to 8N1.
- To change the display configuration or the operating mode (commands O3E, O3D, O4E, O4D, O5E, O5D, O6E, O6D, O7E, O7D, O8E, O8D) it is necessary to send the **CAL START** command to enter the configuration mode. It is not necessary to send the CAL START command to change the parameters related to the speed measurement (tube coefficient, temperature, pressure, full scale for the analog output).
- Send the commands given in table 4.1 to set or read the configuration parameters of the transmitter (the commands that affect the speed or the flow have effect only in the versions with SR option).

TAB. 4.1: serial commands (models with analog output)

Command	Response	Description
Sn	&n sec	Set the response time of index n for the analog outputs: n=1 ⇒ 1 s, n=2 ⇒ 2 s, n=4 ⇒ 4 s
S?	n sec	Reads the response time set for the analog outputs.
O3E	&	Shows alternately speed (or flow) and pressure on display .
O3D	&	Disables the alternating display of speed (or flow) and pressure.
O4E	&	Automatic change of speed resolution on display (0.1 ⇔ 0.01) depending on the measured value.
O4D	&	Fixed centesimal speed resolution on display.
O5E	&	Sets ft/s as speed unit of measurement on display. <i>Note:</i> the symbol ft/s does not appear on display.
O5D	&	Sets m/s as speed unit of measurement on display (default).
O6E	Model description	Enables "Debimo" sensor.
O6D	Model description	Enables Pitot or Darcy sensor (default).

Command	Response	Description
O7E	Model description	Enables flow mode.
O7D	Model description	Enables speed mode (default).
O8E	Model description	Sets m ³ /min as flow unit of measurement .
O8D	Model description	Sets L/s as flow unit of measurement.
CK n.n...	&	Sets the Pitot or Darcy tube coefficient to the value n.n... The value must be between 0.6 and 1.2 (default = 1).
RK	n.nnnn	Reads the value of the Pitot or Darcy tube coefficient set in the transmitter.
D nnnn	nnnn mmq	Sets and reads the duct section in mm ² .
CD n.n	&	Sets the "Debimo" blades coefficient to the value n.n (default=0.8).
CB nnnn.nn...	&	Sets the barometric pressure to the value nnnn.nn... mbar. The value must be between 500 and 1500 mbar (default = 1013.25 mbar).
RB	nnnn.nnn	Reads the value of the barometric pressure in mbar set in the transmitter.
CT n...	&	Sets the airflow temperature in tenths of °C (default = 160 ⇒ 16.0 °C). The value must be between -999 (⇒ -99.9 °C) and 2000 (⇒ 200.0 °C).
RT	n...	Reads the value of the temperature, in tenths of °C, set in the transmitter.
CP nnnn...	&	Sets the differential static pressure (see note 2) in mbar (default = 0).
RP	nnnn...	Reads the value of the differential static pressure set in the transmitter.
CS nnnn	&	In speed mode, sets the full scale speed, in hundredths of m/s, for the analog output (default = see table). The max settable value is 10000 (⇒ 100.00 m/s). In flow mode, sets the full scale flow in L/s or m ³ /min.
RS	nn.nn	In speed mode, reads the speed full scale value, in m/s, for the analog output. In flow mode, reads the flow full scale value, in L/s or m ³ /min, for the analog output.
SV	nn.nn	In speed mode, prints the max measurable speed as a function of the transmitter full scale pressure and values set for the parameters. The value is in the speed unit of measurement set in the transmitter. In flow mode, prints the max measurable flow in L/s or m ³ /min.

Note: To exit the configuration mode after sending the CAL START command, send the CAL END command (the transmitter automatically exits the configuration mode after 5 minutes from the last command sent).

4.2 CONFIGURATION OF THE MODELS WITH RS485 OUTPUT (HD404ST...)

RS485 Modbus address: each transmitter of the network is univocally identified by an address between 1 and **247**. **Transmitters having the same address shall not be present in the network.** The transmitter Modbus address is equal to the sum of the value set with the dip-switches 2...6 (value settable from 0 to 31) and the value set with the serial command WA (value settable from 1 to 216, default = 1). By setting a dip-switch to ON (upwards), the following values are added to the address:

	Dip-switch 2	Dip-switch 3	Dip-switch 4	Dip-switch 5	Dip-switch 6
ON	16	8	4	2	1
OFF	0	0	0	0	0

Example: if the dip-switches 2 and 4 are set to ON, and the dip-switches 3,5 and 6 are set to OFF, the value set with the dip-switches is $16+4=20$. If the value set with the serial command WA is 1 (default value), the transmitter Modbus address is $20+1=21$.

The dip-switches can be set even if the transmitter is powered, and the change is effective immediately.

Configuration via the RS485 serial port:

In order to change the settings, proceed as follows:

- Connect the transmitter RS485 output to the PC RS232 (through a RS485/RS232 converter) or USB (through a RS485/USB converter, for example the **RS48** cable) port. If a RS485/USB converter is used, install in the PC the related USB drivers.
- To enable the configuration mode, set the **dip-switch 1** (the one closest to the terminal block) to **ON** (upwards), then power the transmitter.

Note: the dip-switch 1 can be changed from OFF to ON even when the instrument is powered; in this case it is however necessary, after setting the dip-switch to ON, to press briefly (less than 0.5 seconds) the CAL ZERO button to enable the configuration mode (the transmitter model information appears on display, if present). Alternatively, power cycle the transmitter.

- On the PC, run a serial communication software, set the baud rate to 57600 and the communication parameters to 8N1.
- Send the **CAL START** command (the command is required to change the configuration; to read the value of the parameters, the command is not required).
- Send the commands given in table 4.2 to set or read the configuration parameters of the transmitter (the commands that affect the speed or the flow have effect only in the versions with SR option).

TAB. 4.2: serial commands (models with RS485 Modbus-RTU output)

Command	Description
AVGn	Set the response time of index n for the measurement: n=0 \Rightarrow 0.125 s, n=1 \Rightarrow 1 s, n=2 \Rightarrow 2 s, n=4 \Rightarrow 4 s
AVG?	Reads the response time set for the measurement.
DU0	Shows pressure in Pa on display.
DUF	Shows flow in l/min on display (only in the versions with SR option).
DUV	Shows speed in m/s on display (only in the versions with SR option).
OPT3E	Shows alternately speed (or flow) and pressure on display.

Command	Description
OPT3D	Disables the alternating display of speed (or flow) and pressure.
OPT4E	Automatic change of speed resolution on display (0,1 ↔ 0,01) depending on the measured value.
OPT4D	Fixed centesimal speed resolution on display.
OPT6E	Enables "Debimo" sensor.
OPT6D	Enables Pitot sensor (default).
WK n.n...	Sets the Pitot or Darcy tube coefficient to the value n.n... The value must be between 0.6 and 1.2 (default = 1).
RK	Reads the value of the Pitot or Darcy tube coefficient set in the transmitter.
WD n.n...	Sets the "Debimo" sensor coefficient to the value n.n... The value must be between 0.6 and 1.2 (default = 1).
RD	Reads the value of the "Debimo" sensor coefficient set in the transmitter.
WS nnnn	Sets the duct section in mm ² .
RS	Reads the duct section in mm ² .
WB nnnn.nn...	Sets the barometric pressure to the value nnnn.nn... hPa. The value must be between 100 and 2000 hPa (default = 1013.25 hPa).
RB	Reads the value of the barometric pressure in hPa set in the transmitter.
WT nn.n	Sets the airflow temperature in °C. The value must be between -20.0 °C and +60.0 °C.
RT	Reads the value of the temperature in °C set in the transmitter.
WP nnnn...	Sets the differential static pressure (see note 2) in Pa (default = 0).
RP	Reads the value of the differential static pressure set in the transmitter.
Auto-zero	
ZFn	Sets the auto-zero interval of index n (only in the versions with AZ option): n=0 ⇒ disabled n=1 ⇒ 5 min n=2 ⇒ 10 min n=3 ⇒ 20 min n=4 ⇒ 30 min n=5 ⇒ 60 min Default = 60 min
ZF?	Reads the auto-zero interval set (only in the versions with AZ option)
Modbus parameters	
WA n...n	Sets the Modbus base address to the value n...n. The value must be between 1 and 216 (default = 1). Warning: the actual Modbus address of the transmitter is equal to the base address set with this command plus the value set with the dip-switches. Note: in the reply to the command, the previous actual address appears; the new address will appear in the replies to the next commands.
BAUD r...r	Sets the Modbus Baud Rate to the value r...r. The acceptable values are 9600 and 19200 (default = 19200). If the command is sent without the parameter r...r, the current setting is obtained.
PAR p	Sets the Modbus communication parameters of index p: p=O ⇒ 801 p=N ⇒ 8N2 p=E ⇒ 8E1 If the command is sent without the index p, the current setting is obtained (default = 8E1).

Note: the replies of the HD404ST... transmitters always start with the address of the connected transmitter. For example, sending the RB command to a transmitter with Modbus address 1, the reply is "001: ATM pressure = 1013.250 hPa".

Note: To exit the configuration mode after sending the CAL START command, send the CAL END command (the transmitter automatically exits the configuration mode after 5 minutes from the last command sent).

4.3 NOTES ON THE CONFIGURATION OF THE MODELS WITH SR OPTION

Resolution of the speed measurement: The speed is calculated from the pressure measure through a quadratic relationship. For this reason, the speed resolution is lower for low pressure values measured, and the change of the speed measurement on the display appears rather discontinuous if the fixed centesimal resolution is used. If a more uniform speed change on display is desired, enable the automatic speed resolution change as a function of the measured value (serial command O4E in the models HD404T..., serial command OPT4E in the models HD404ST...).

Flow measurement: the transmitter can be set in flow measurement mode (serial command O7E in the models HD404T..., serial command DUF in the models HD404ST...). The flow is calculated from the speed measurement and the duct section set. The flow mode is available both with Pitot and "Debimo" sensors.

4.4 ERROR MESSAGES ON DISPLAY

Undr: The measured value is less than the minimum measurable value.

OvEr: The measured value exceeds the maximum measurable value.

CAL Error: It appears at the end of the zero calibration if the maximum offset value possible to be corrected is exceeded.

5 MODBUS-RTU PROTOCOL (HD404ST...)

To operate with the Modbus-RTU protocol be sure that the **dip-switch 1** (the one closest to the terminal block) is set to **OFF** (downwards). The dip-switch can be set to OFF even if the transmitter is powered, and the change is effective immediately.

Below is the list of registers:

TAB. 5.1: Input Registers

Address	Description	Format
3	Pressure in tenths of Pa (only HD404ST2...)	16-bit integer
4	Pressure in Pa (only HD404ST2... and HD404ST4...)	16-bit integer
5	Pressure in daPa (only HD404ST4... and HD404ST5AZ...)	16-bit integer
6	Pressure in hPa (only HD404ST4 without AZ option and HD404ST5...)	16-bit integer
7	Pressure in kPa (only HD404ST5...)	16-bit integer
8	Pressure in hundredths of mmH ₂ O (only HD404ST2... and HD404ST4AZ...)	16-bit integer
9	Pressure in tenths of mmH ₂ O (only HD404ST2... and HD404ST4...)	16-bit integer
10	Pressure in mmH ₂ O (only HD404ST4... and HD404ST5AZ...)	16-bit integer
11	Pressure in thousandths of inchH ₂ O (only HD404ST2... and HD404ST4AZ...)	16-bit integer
12	Pressure in hundredths of inchH ₂ O (only HD404ST4...)	16-bit integer
13	Pressure in tenths of inchH ₂ O (only HD404ST4 without AZ option and HD404ST5...)	16-bit integer
14	Pressure in inchH ₂ O (only HD404ST5...)	16-bit integer
15	Pressure in thousandths of mmHg (only HD404ST4AZ...)	16-bit integer
16	Pressure in hundredths of mmHg (only HD404ST4...)	16-bit integer
17	Pressure in tenths of mmHg (only HD404ST4 without AZ option and HD404ST5AZ...)	16-bit integer
18	Pressure in mmHg (only HD404ST5...)	16-bit integer
19	Pressure in thousandths of PSI (only HD404ST4 without AZ option)	16-bit integer
20	Pressure in hundredths of PSI (only HD404ST4 without AZ option and HD404ST5...)	16-bit integer
21	Speed in hundredths of m/s (only models with SR option)	16-bit integer
22	Speed in hundredths of ft/s (only models with SR option)	16-bit integer
23	Flow in l/s (only models with SR option)	16-bit integer
24	Flow in l/min (only models with SR option)	16-bit integer
25	Flow in m ³ /min (only models with SR option)	16-bit integer
26	Error register	16-bit integer

Note: Reading a register not available for a particular model returns the value -32768 (0x8000).

Note: If the pressure measurement is negative, the speed and flow registers return zero.

Error register

The bits of the error register signal, if set to 1, anomalies in the measurement. The bit 0 (the less significant one) indicates a measurement over-range of the transmitter. The bit 1 indicates whether the measurement is less than the minimum measurable (under-range). The bits 2 and 3 indicate sensor errors.

TAB. 5.2: Holding Registers

Address	Description	Format
100	Modbus base address (from 1 to 216) Warning: the actual Modbus address of the transmitter is equal to the base address set in this register plus the value set with the dip-switches.	16-bit integer
101	Modbus Baud Rate Acceptable values: 3 (\Rightarrow 9600) and 4 (\Rightarrow 19200)	16-bit integer
102	Modbus communication parameters Acceptable values: 1 (\Rightarrow 8N2), 2 (\Rightarrow 8E1) and 4 (\Rightarrow 8O1)	16-bit integer

The Modbus Holding Registers allow setting the same Modbus parameters that can be set via the serial commands WA, BAUD and PAR. Use the 06h (Write Single Register) and 03h (Read Holding Registers) function codes to write and read respectively the content of the registers.

To make the changes of the Holding Registers content active and permanent, write the hexadecimal value FF00 in the Coil Register with address 2 by using the 05h function code (Write Single Coil).

TAB. 5.3: Coils

Address	Description
2	Activation and permanent storage of the Holding Registers content changes.

6 INSTRUMENT STORAGE

Instrument storage conditions:

- Temperature: -20...+70 °C.
- Humidity: less than 90 %RH no condensation.
- In storage, avoid places where:
 - humidity is high;
 - the instrument is exposed to direct sun radiation;
 - the instrument is exposed to a high temperature source;
 - high vibration levels are present;
 - the instrument may be exposed to vapor, salt and/or corrosive gas.

7 SAFETY INSTRUCTION

General safety instructions

The instrument has been manufactured and tested in accordance with the safety standard EN61010-1:2010 "Safety requirements for electrical equipment for measurement, control and laboratory use" and has left the factory in perfect safety technical conditions.

The instrument proper operation and operating safety can be ensured only if all standard safety measures as well as the specific measures described in this manual are followed.

The instrument proper operation and operating safety can be ensured only in the climatic conditions specified in this manual.

Do not use the instruments in places where there are:

- Corrosive or flammable gases.
- Direct vibrations or shocks to the instrument.
- High-intensity electromagnetic fields, static electricity.

User obligations

The instrument operator shall follow the directives and regulations below that refer to the treatment of dangerous materials:

- EEC directives on workplace safety.
- National law regulations on workplace safety.
- Accident prevention regulations.

8 ACCESSORIES ORDERING CODES

Accessories included:

- Silicone tube, internal \varnothing 5 mm / external \varnothing 8 mm, length 2 m.
- Two plastic fittings (HD434T.5).

Optional accessories:

RS27 RS232 null-modem serial connection cable with SubD 9-pin connector on the PC side and 3-pole connector on the instrument side.

CP27 Connection cable with built-in USB/RS232 converter. USB connector on the PC side and 3-pole connector on the instrument side.

RS48 Cable for RS485 connection with built-in USB/RS485 converter. The cable has USB connector for PC and 3 separate wires for the instruments.

AP3719 Flow port for square or cylindrical duct. Supplied with two pieces of silicone tube internal \varnothing 4 mm / external \varnothing 6 mm, length 1 m.

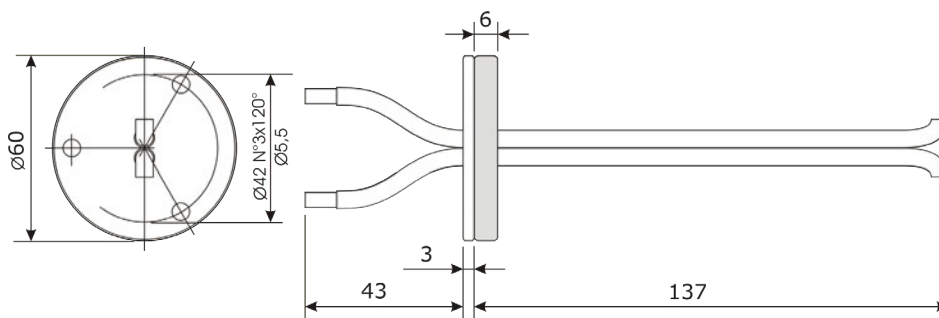

AP3721 Plastic flow port for cylindrical duct. Supplied with two pieces of silicone tube, internal \varnothing 4 mm / external \varnothing 6 mm, length 1 m.

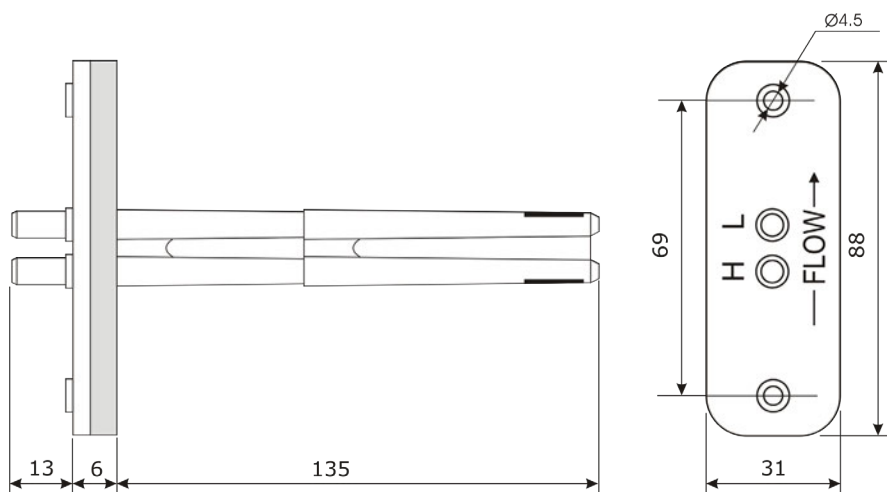

Pitot tubes:

In stainless steel, for measuring the air speed. The models with TC suffix also measure the temperature with K thermocouple sensor. Supplied with two pieces of silicone tube, internal Ø 4 mm / external Ø 6 mm, length 1.5 m.

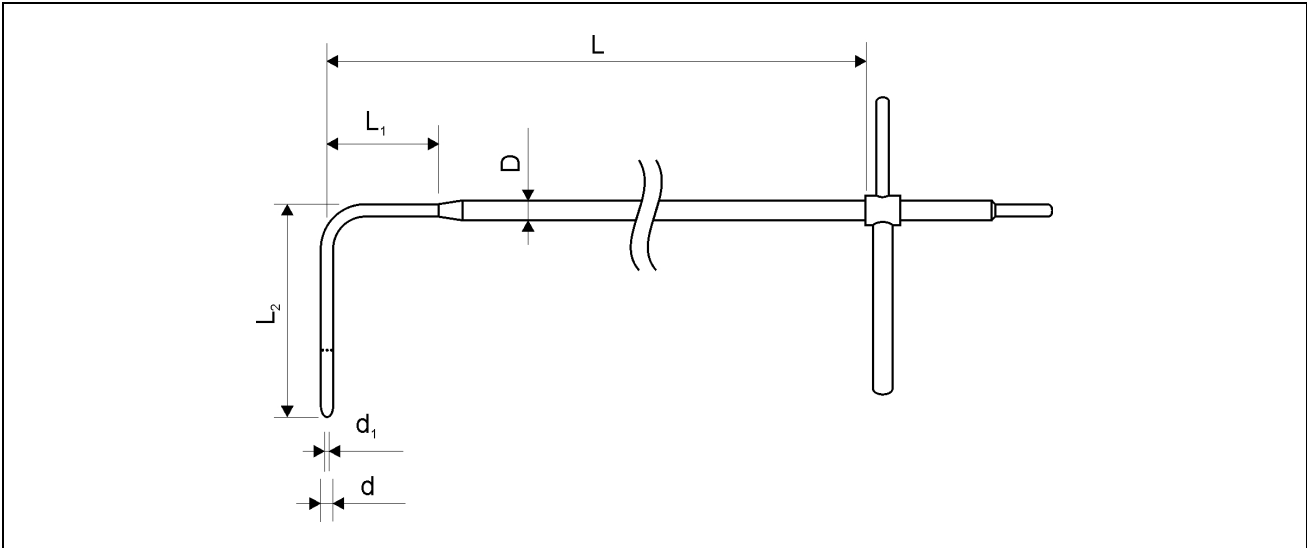

	d (mm)	d ₁ (mm)	D (mm)	L (mm)	L ₁ (mm)	L ₂ (mm)	Operating temp.	Temp. sensor	Material
T1-300	3	1	6	300	30	72	0...600 °C	---	AISI 316
T2-400	5	2	8	400	45	120		---	
T3-800	8	3.2	8	800	---	192		---	
T3-800TC	8	3.2	8	800	---	192		TC K	

For other dimensions, please contact Delta OHM – sales@deltaohm.com

PW K thermocouple extension cable. Length 2 m, miniature connector. For Pitot tubes with K thermocouple sensor.

Delta OHM metrology laboratories LAT N° 124 are ISO/IEC 17025 accredited by ACCREDIA for Temperature, Humidity, Pressure, Photometry / Radiometry, Acoustics and Air Velocity. They can supply calibration certificates for the accredited quantities.

NOTES

WARRANTY

The manufacturer is required to respond to the "factory warranty" only in those cases provided by Legislative Decree 6 September 2005 - n. 206. Each instrument is sold after rigorous inspections; if any manufacturing defect is found, it is necessary to contact the distributor where the instrument was purchased from. During the warranty period (24 months from the date of invoice) any manufacturing defects found will be repaired free of charge. Misuse, wear, neglect, lack or inefficient maintenance as well as theft and damage during transport are excluded. Warranty does not apply if changes, tampering or unauthorized repairs are made on the product. Solutions, probes, electrodes and microphones are not guaranteed as the improper use, even for a few minutes, may cause irreparable damages.

The manufacturer repairs the products that show defects of construction in accordance with the terms and conditions of warranty included in the manual of the product. For any dispute, the competent court is the Court of Padua. The Italian law and the "Convention on Contracts for the International Sales of Goods" apply.

TECHNICAL INFORMATION

The quality level of our instruments is the result of the continuous product development. This may lead to differences between the information reported in the manual and the instrument you have purchased.

We reserves the right to change technical specifications and dimensions to fit the product requirements without prior notice.

DISPOSAL INFORMATION

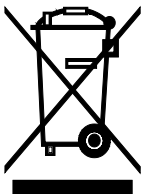

Electrical and electronic equipment marked with specific symbol in compliance with 2012/19/EU Directive must be disposed of separately from household waste. European users can hand them over to the dealer or to the manufacturer when purchasing a new electrical and electronic equipment, or to a WEEE collection point designated by local authorities. Illegal disposal is punished by law.

Disposing of electrical and electronic equipment separately from normal waste helps to preserve natural resources and allows materials to be recycled in an environmentally friendly way without risks to human health.

CE RoHS



senseca

Please note our new name:
Senseca Italy Srl
Via Marconi 5, 35030 Padua, Italy
Documents are in the process of being changed.