

English

## Operating manual

Photometric probe

**LPPHOT02**



Members of GHM GROUP:

**GREISINGER**

**HONSBERG**

**Martens**

**Delta OHM**

**VAL.CO**

[www.deltaohm.com](http://www.deltaohm.com)

**Keep for future reference.**

# TABLE OF CONTENTS

<b>1</b>	<b>INTRODUCTION .....</b>	<b>3</b>
<b>2</b>	<b>WORKING PRINCIPLE.....</b>	<b>4</b>
<b>3</b>	<b>INSTALLATION .....</b>	<b>5</b>
<b>4</b>	<b>ELECTRICAL CONNECTIONS.....</b>	<b>8</b>
4.1	LPPHOT02 CONNECTIONS .....	8
4.2	LPPHOT02AC CONNECTIONS .....	9
4.3	LPPHOT02AV CONNECTIONS .....	9
<b>5</b>	<b>MEASUREMENT .....</b>	<b>10</b>
5.1	LPPHOT02.....	10
5.2	LPPHOT02AC.....	10
5.3	LPPHOT02AV.....	10
<b>6</b>	<b>MAINTENANCE.....</b>	<b>11</b>
<b>7</b>	<b>TECHNICAL SPECIFICATIONS.....</b>	<b>12</b>
<b>8</b>	<b>SAFETY INSTRUCTIONS.....</b>	<b>13</b>
<b>9</b>	<b>ACCESSORIES ORDERING CODES .....</b>	<b>14</b>

# 1 INTRODUCTION

The **LPPHOT02** probe measures illuminance (lux), defined as the ratio between the luminous flux (lumen) through a surface and the surface area itself (m<sup>2</sup>).

The spectral response curve of a photometric probe is equal to the human eye, known as **standard photopic curve V(λ)**. The difference in spectral response between the LPPHOT02 and the standard photopic curve V(λ) is evaluated through the calculation of the error  $f'_1$ .

The probe has been designed for **outdoor installation for long periods**, in particular for the measurement of daylight in climatological and meteorological applications.

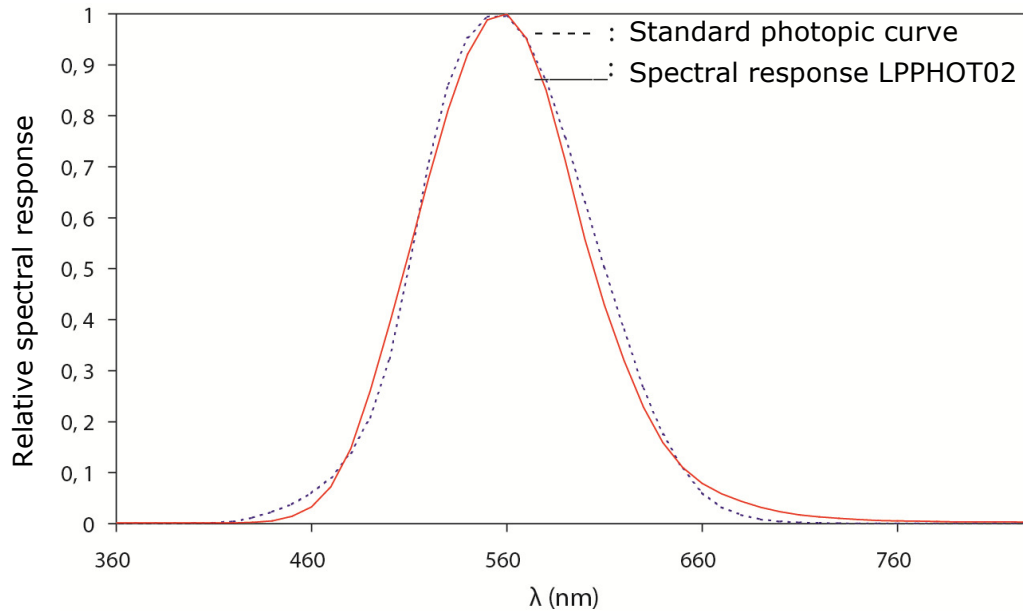
Available in the following versions:

- **LPPHOT02:** PASSIVE.
- **LPPHOT02AC:** ACTIVE with 4..20 mA CURRENT output.
- **LPPHOT02AV:** ACTIVE with 0..1 or 0..5 or 0..10 V VOLTAGE output to be defined when ordering.

Each luxmeter is individually calibrated at the factory and is distinguished by its own calibration factor. The calibration is performed by comparison with the reference luxmeter of the Delta OHM metrology laboratory, using an illuminant "A" as a source, as required by CIE publication N°69 "Methods of characterizing illuminance meters and luminance meters: Performance, characteristics and specifications".

## 2 WORKING PRINCIPLE

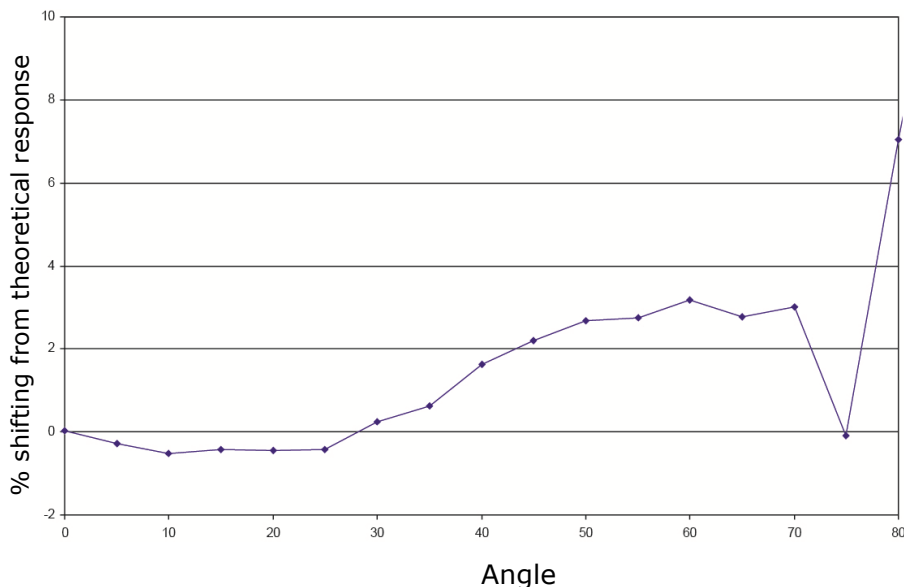
LPPHOT02 probe is based on a solid state sensor, whose spectral response has been adapted to that of the human eye using a special filter. The relative spectral response is reported on figure 2.1.



**Fig. 2.1**

The luxmeter is provided with a 50 mm external diameter dome in order to supply a suitable protection of the sensor to the weather agents.

The response in accordance with the cosine law has been obtained thanks to the particular shape of the diffuser and of the housing. The deviation between the theoretical response and the measured one is shown in the Fig. 2.2.



**Fig. 2.2**

The excellent relation between the response of the luxmeter and the cosine law allows using the instrument also when the sun has a very low raising.

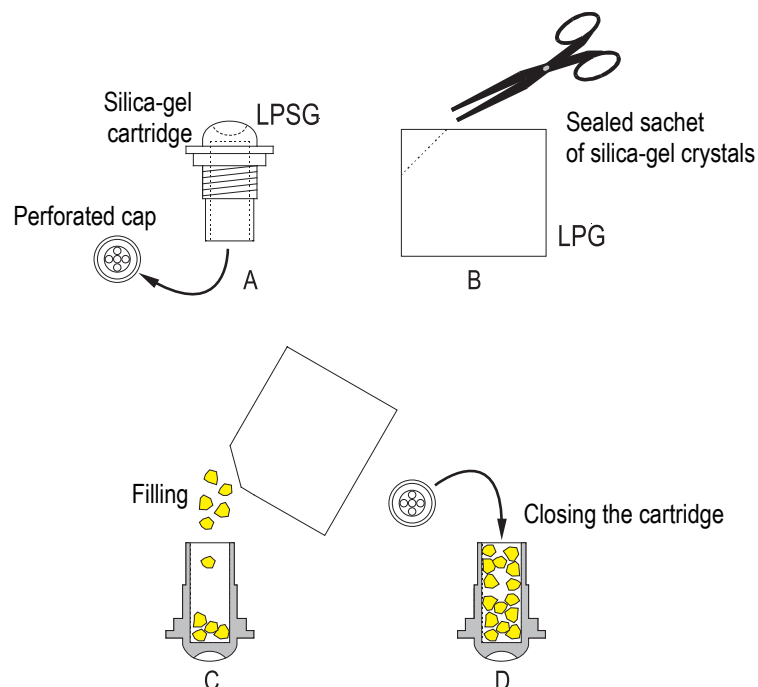
### 3 INSTALLATION

Before installing the sensor, refill the cartridge containing silica-gel crystals. Silica gel absorbs humidity in the dome chamber and prevents, in particular climatic conditions, condensation on the internal walls of the domes and measurement alteration.

Do not touch the silica gel crystals with your hands while refilling the cartridge. Carry out the following instructions in an environment as drier as possible:

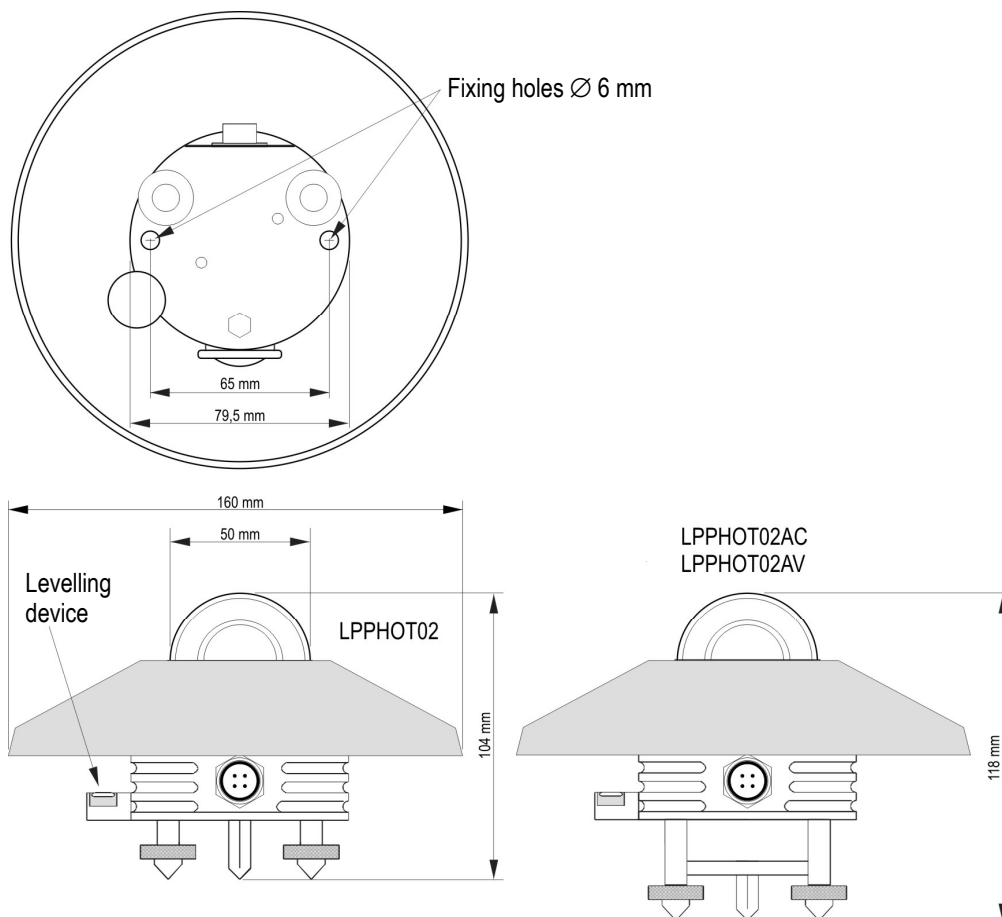
1. Loosen the three screws that fix the white shade disk.
2. Unscrew the silica gel cartridge using a coin.
3. Remove the cartridge perforated cap.
4. Open the sachet containing silica gel (supplied with the instrument).
5. Fill the cartridge with the silica gel crystals.
6. Close the cartridge with its own cap, paying attention that the sealing O-ring be properly positioned.
7. Screw the cartridge to the sensor body using a coin.
8. Check that the cartridge is screwed tightly (if not, silica gel life will be reduced).
9. Position the shade disk and screw it with the screws.
10. The sensor is ready for use.

The figure below shows the operations necessary to fill the cartridge with the silica gel crystals.

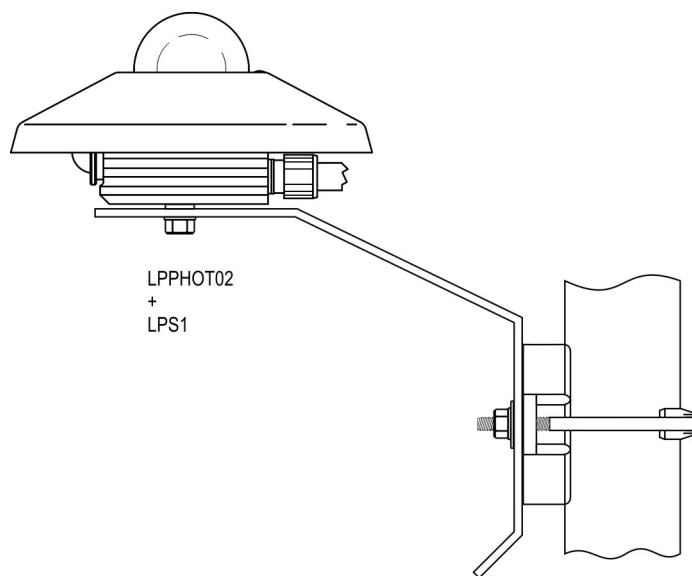
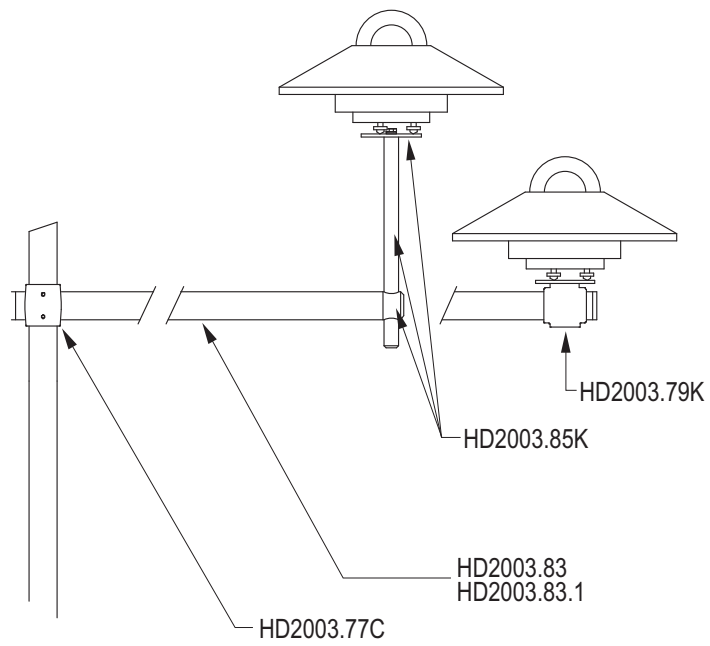


**Fig. 3.1: filling the silica-gel cartridge**

- The sensor must be mounted in an easy-to-reach location in order to clean the dome regularly and carry out maintenance. At the same time, make sure that no buildings, constructions, trees or obstructions exceed the horizontal plane where the sensor lies. If this is not possible, select a site where obstructions in the path of the sun from sunrise to sunset do not exceed 5 degrees of elevation.
- The sensor must be located far from any kind of obstruction, which might reflect sunlight (or sun shadow) onto the sensor itself.
- For fixing, use the holes on the sensor body (remove the shade disk to access the holes and reposition it after mounting) or the suitable accessories (see the figures below). In order to allow an accurate horizontal positioning, the sensor is equipped with a levelling device: the adjustment is made by means of the two levelling screws that allow adjusting the sensor inclination. The mast height does not exceed the sensor plane to avoid measurement errors caused by any reflection or shadow of the mast itself.
- It is preferably to thermally insulate the sensor from its mounting bracket ensuring, at the same time, a good electrical contact to ground.



**Fig. 3.2: fixing holes and levelling device**



**Fig. 3.3: fixing accessories**

## 4 ELECTRICAL CONNECTIONS

LPPHOT02... has a 4-pole connector and uses the **CPM12AA4... optional** cables.



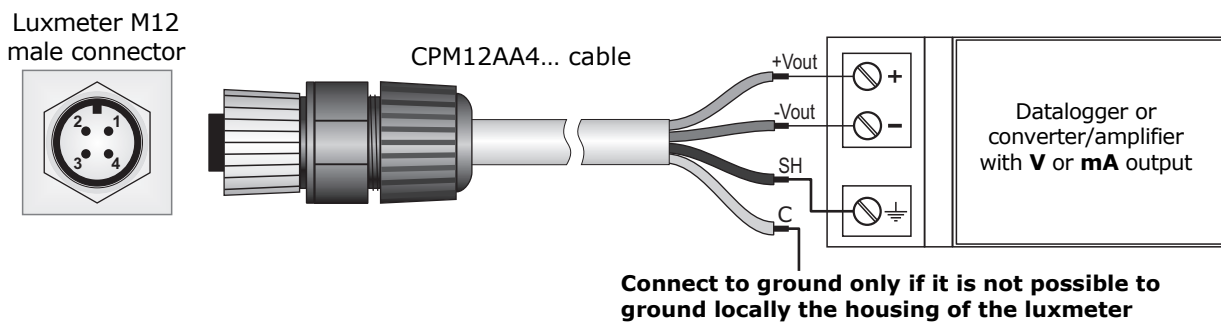
**The metallic housing of the sensor should preferably be grounded ( $\perp$ ) locally. In this case, do not connect the wire of the cable corresponding to the housing to prevent ground loops.**

**Only if it is not possible to ground locally the metallic case of the sensor, connect the wire of the cable corresponding to the housing to ground.** Note: in LPPHOT02AV the housing is not connected to the connector.

### 4.1 LPPHOT02 CONNECTIONS

The luxmeter LPPHOT02 is **passive** and does not require power supply. It is to be connected either to a millivoltmeter or to a data acquisition system. Typically, the luxmeter output signal does not exceed 150 mV. In order to better exploit the luxmeter features, the readout instrument should have 1  $\mu$ V resolution.

Connector	Function	Color
1	+Vout	Red
2	-Vout	Blue
3	Housing (C)	White
4	Cable shield (SH)	Black



**Fig. 4.1: LPPHOT02 connections**



## 4.2 LPPHOT02AC CONNECTIONS

The LPPHOT02AC luxmeter has **4...20 mA** output and requires **10...30 Vdc** external power supply. It is to be connected to a power supply and an instrument with 4...20 mA input as shown in fig. 4.2. The load resistance of the instrument reading the signal must be  $\leq 500 \Omega$ .

Connector	Function	Color
1	Positive (Iin)	Red
2	Negative (Iout)	Blue
3	Housing (C)	White
4	Cable shield (SH)	Black

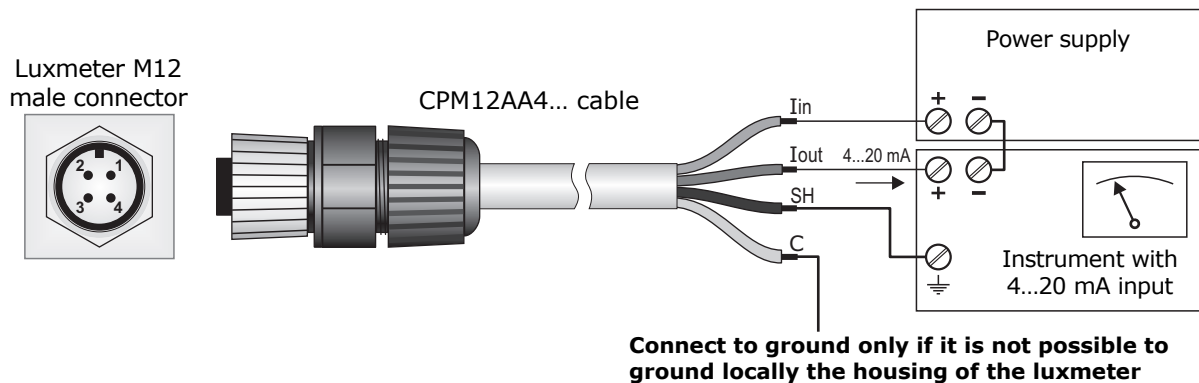


Fig. 4.2: LPUVA02AC connections

## 4.3 LPPHOT02AV CONNECTIONS

The LPPHOT02AV luxmeter has **0...1 V**, **0...5 V** or **0...10 V** output (depending on the ordered output) and requires external power supply: **10...30 Vdc** for 0...1 V and 0...5 V outputs, **15...30 Vdc** for 0...10 V output. It is to be connected to a power supply and an instrument with voltage input as shown in fig. 4.3. The load resistance of the instrument reading the signal must be  $\geq 100 \text{ k}\Omega$ .

Connector	Function	Color
1	Output positive (+Vout)	Red
2	Output negative Power supply negative (GND)	Blue
3	Power supply positive (+Vdc)	White
4	Cable shield (SH)	Black

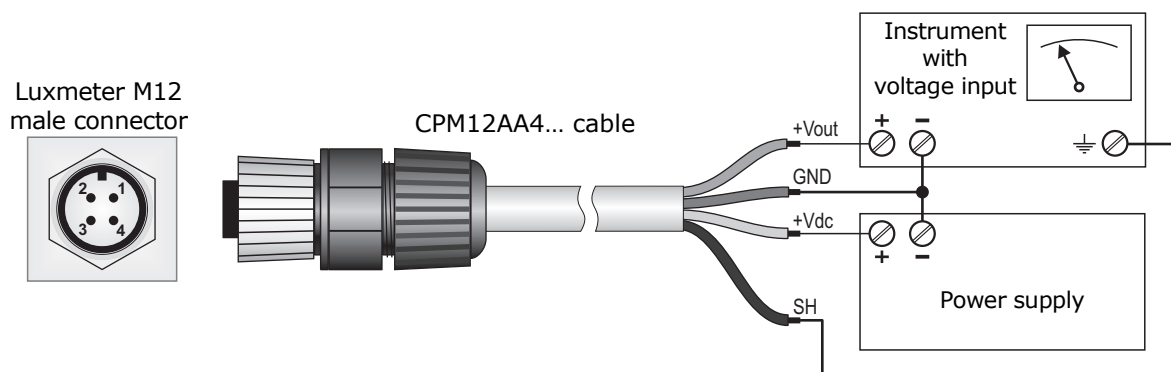


Fig. 4.3: LPPHOT02AV connections

## 5 MEASUREMENT

Below are the ways to calculate the illuminance.

### 5.1 LPPHOT02

---

Each luxmeter is distinguished by its own sensitivity (or calibration factor) **S** expressed in mV/klux and shown in the label on the sensor (and in the calibration report).

The irradiance **E<sub>e</sub>** is obtained by measuring with a multimeter the difference of potential **DDP** at the ends of the sensor and applying the following formula:

$$E_e = DDP / S$$

where:

**E<sub>e</sub>** is the illuminance expressed in klux;

**DDP** is the difference of potential expressed in mV measured by the multimeter;

**S** is the sensitivity of the luxmeter expressed in mV/klux.

### 5.2 LPPHOT02AC

---

The 4...20 mA output signal corresponds to 0...150 klux illuminance range.

The illuminance **E<sub>e</sub>** is obtained by measuring with a multimeter the current **I<sub>out</sub>** absorbed by the sensor and applying the following formula:

$$E_e = 9.375 \cdot (I_{out} - 4mA)$$

where:

**E<sub>e</sub>** is the illuminance expressed in klux;

**I<sub>out</sub>** is the current expressed in mA absorbed by the luxmeter.

### 5.3 LPPHOT02AV

---

The output signal (0...1 V, 0...5 V or 0...10 V depending on the version) corresponds to 0...150 klux illuminance range.

The illuminance **E<sub>e</sub>** is obtained by measuring with a multimeter the output voltage **V<sub>out</sub>** of the sensor and applying the following formula:

$$E_e = 150 \cdot V_{out} \text{ for the version 0...1 V}$$

$$E_e = 30 \cdot V_{out} \text{ for the version 0...5 V}$$

$$E_e = 15 \cdot V_{out} \text{ for the version 0...10 V}$$

where:

**E<sub>e</sub>** is the illuminance expressed in klux;

**V<sub>out</sub>** is the output voltage expressed in V measured by the multimeter.

## 6 MAINTENANCE

In order to grant measurements high accuracy, it is important to keep the glass dome clean. Consequently, the more the dome will be kept clean, the more measurements will be accurate.

You can wash it using water and standard papers for lens. If necessary, use pure ETHYL alcohol. After using alcohol, clean again the dome with water only.

Because of the high temperature changes between day and night, some condensation might appear on the sensor dome. In this case the performed reading is highly over-estimated. To minimize the condensation, the sensor is provided with a cartridge containing dessicant material (silica-gel). The efficiency of the silica-gel crystals decreases over time while absorbing humidity. Silica-gel crystals are efficient when their colour is **yellow**, while they turn **white/translucent** as soon as they lose their efficiency. Read instructions at chapter 3 about how to replace the silica-gel crystals. Silica-gel typical lifetime goes from 2 to 6 months depending on the environment where the sensor works.

To exploit all the sensor features, it is highly recommended that the calibration be checked annually.

## 7 TECHNICAL SPECIFICATIONS

<b>Measuring range</b>	0...150 klux
<b>Typical sensitivity</b>	0.5...2 mV/klux
<b>Viewing range</b>	$2\pi$ sr
<b>Impedance</b>	0.5...1 K $\Omega$
<b>Spectral range</b>	Standard photopic curve
<b>Response time</b>	<0.5 s (95%)
<b>Output</b>	LPPHOT02 = mV/klux LPPHOT02 <b>AC</b> = 4...20 mA LPPHOT02 <b>AV</b> = 0...1, 0...5, 0...10 V (depending on the model)
<b>Power supply</b>	10...30 Vdc (15...30 Vdc only for 0...10 V output)
<b>Operating temperature</b>	-40 °C...+80 °C
<b>Response according to the cosine law</b>	< 8 % (0...80°)
<b>Long term instability (1 year)</b>	<  $\pm 3$   %
<b>Error <math>f'_1</math></b>	<9 %
<b>Non linearity</b>	<  $\pm 1$   %
<b>Temperature response</b>	< 0.1 %/°C
<b>Weight</b>	900 g approx.

## 8 SAFETY INSTRUCTIONS

### General safety instructions

The instrument has been manufactured and tested in accordance with the safety standard EN61010-1:2010 "Safety requirements for electrical equipment for measurement, control and laboratory use" and has left the factory in perfect safety technical conditions.

The instrument proper operation and operating safety can be ensured only if all standard safety measures as well as the specific measures described in this manual are followed.

Do not use the instruments in places where there are:

- Corrosive or flammable gases.
- Direct vibrations or shocks to the instrument.
- High-intensity electromagnetic fields, static electricity.

### User obligations

The instrument operator shall follow the directives and regulations below that refer to the treatment of dangerous materials:

- EEC directives on workplace safety.
- National law regulations on workplace safety.
- Accident prevention regulations.

## 9 ACCESSORIES ORDERING CODES

The luxmeter is supplied with shade disk, silica-gel cartridge, 2 spare sachets, levelling device, M12 connector and Calibration Report.

### Accessories

<b>LPSP1</b>	UV-resistant shade disk (spare part).
<b>LPS1</b>	Only attachment bracket, suitable for mast with diameter 40...50 mm. Installation on horizontal or vertical mast.
<b>LPRING02</b>	Base with levelling device and adjustable holder for mounting the pyranometer in an inclined position (specify upon ordering on which luxmeter model has to be mounted).
<b>HD2003.79K</b>	Kit to mount the luxmeter on $\varnothing$ 40 mm clamping. To install the luxmeter on a transverse mast.
<b>LPS6</b>	Kit for the installation of the luxmeter. The kit includes: 750 mm mast, base fitting, graduated support plate, bracket for luxmeter.
<b>CPM12AA4...</b>	4-pole cable. 4-pole M12 connector on one end, open wires on the other end. Available length 2 m (CPM12AA4.2), 5 m (CPM12AA4.5) or 10 m (CPM12AA4.10).
<b>LPSG</b>	Cartridge to contain desiccant silica-gel crystals, complete with O-ring and cap (spare part).
<b>LPG</b>	Pack of 5 sachets of silica-gel crystals.

**DELTA OHM metrology laboratories LAT N° 124 are ISO/IEC 17025 accredited by ACCREDIA for Temperature, Humidity, Pressure, Photometry / Radiometry, Acoustics and Air Velocity. They can supply calibration certificates for the accredited quantities.**

## NOTES

---

## WARRANTY

The manufacturer is required to respond to the "factory warranty" only in those cases provided by Legislative Decree 6 September 2005 - n. 206. Each instrument is sold after rigorous inspections; if any manufacturing defect is found, it is necessary to contact the distributor where the instrument was purchased from. During the warranty period (24 months from the date of invoice) any manufacturing defects found will be repaired free of charge. Misuse, wear, neglect, lack or inefficient maintenance as well as theft and damage during transport are excluded. Warranty does not apply if changes, tampering or unauthorized repairs are made on the product. Solutions, probes, electrodes and microphones are not guaranteed as the improper use, even for a few minutes, may cause irreparable damages.

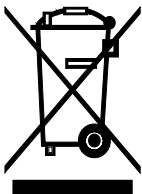
The manufacturer repairs the products that show defects of construction in accordance with the terms and conditions of warranty included in the manual of the product. For any dispute, the competent court is the Court of Padua. The Italian law and the "Convention on Contracts for the International Sales of Goods" apply.

## TECHNICAL INFORMATION

The quality level of our instruments is the result of the continuous product development. This may lead to differences between the information reported in the manual and the instrument you have purchased.

We reserves the right to change technical specifications and dimensions to fit the product requirements without prior notice.

## DISPOSAL INFORMATION



Electrical and electronic equipment marked with specific symbol in compliance with 2012/19/EU Directive must be disposed of separately from household waste. European users can hand them over to the dealer or to the manufacturer when purchasing a new electrical and electronic equipment, or to a WEEE collection point designated by local authorities. Illegal disposal is punished by law.

Disposing of electrical and electronic equipment separately from normal waste helps to preserve natural resources and allows materials to be recycled in an environmentally friendly way without risks to human health.

CE RoHS



**senseca**

**Please note our new name:**  
Senseca Italy Srl  
Via Marconi 5, 35030 Padua, Italy  
*Documents are in the process of being changed.*