

## TP32MTT.03.A/B/C



### TP32MTT.03.A/B/C AIR AND SOIL TEMPERATURE PROBES

The TP32MTT.03.A/B/C temperature probes measure the air and/or soil temperature by means of a 4-wire Pt100 sensor.

They are provided with a protective screen which allows to detect the temperature without that the measurement is influenced by solar radiation. The position of the sensor inside the screen is such as to prevent it from being invested by radiation. The screen is made of UV-resistant ASA technopolymer, with low thermal conductivity and high reflection.

There are single probes available, for the measurement of only air or soil temperature, and a double probe for simultaneous measurement of the air and soil temperature.

- **TP32MTT.03.A** : single probe for the measurement of the soil temperature at a depth of 5 cm
- **TP32MTT.03.B** : double probe for the measurement of air and soil temperature at  $\pm 5$  cm from the soil
- **TP32MTT.03.C** : single probe for the measurement of the air temperature

The probes TP32MTT.03.A and TP 32MTT.03.B are fixed by means of a metal spike to be driven into the ground. The probe TP32MTT.03.C is attached to a bracket made of Anticorodal aluminium, powder coated, white.

Length of the cable 2, 5 or 10 m. The cable is terminated with open wires.

Technical specifications	
Sensor	4-wire Pt100
Class	1/3 DIN
Working temperature	-40...+85 °C
Connection	2, 5 or 10 m cable terminating with open wires. 8-pole cable for TP32MTT.03.B 4-pole cable for TP32MTT.03.A and TP32MTT.03.C
Degree of protection	IP 67

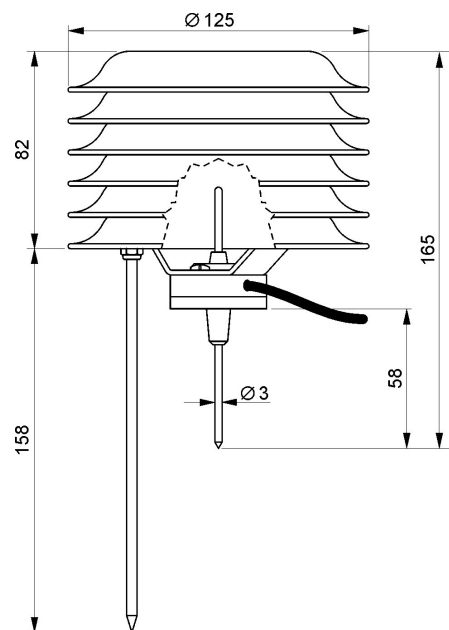
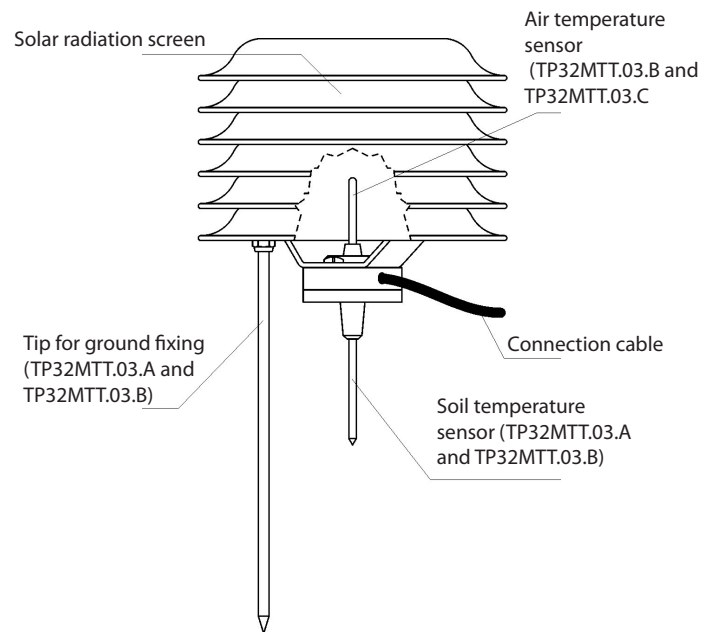

## INSTALLATION

The probe TP32MTT.03.C for the measurement of only air temperature can be fixed on a flat support by means of the bracket HD9007T29.1, or on a mast having diameter from 25 to 44 mm by means of mounting kit HD9007T29K.

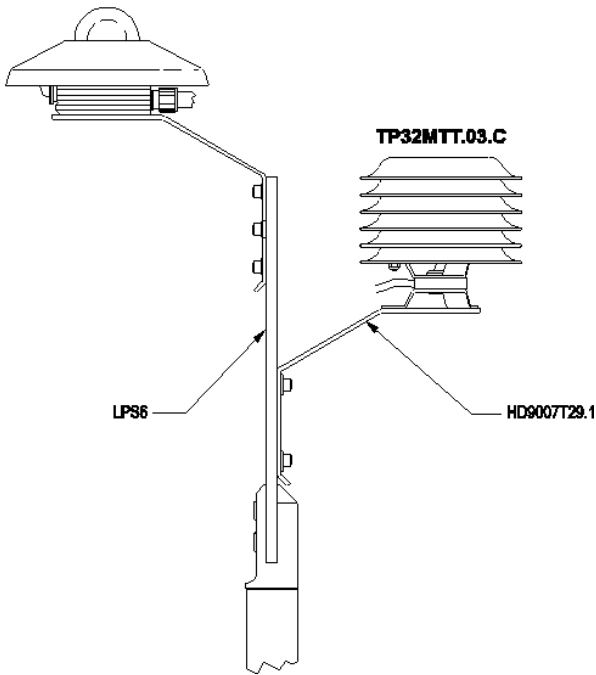

Installation with HD9007T29.1 bracket

Installation on  $\varnothing 25 \dots 44$  mm mast with HD9007T29K kit

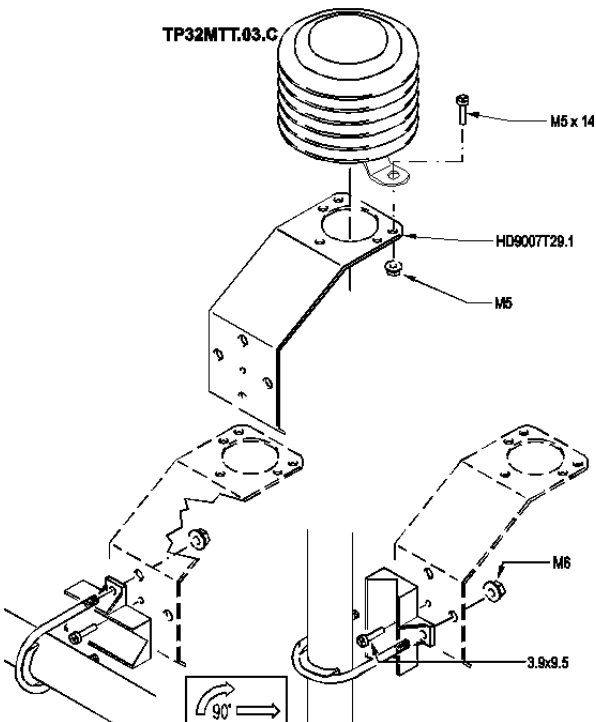

The probes with soil temperature sensor TP32MTT.03.A and TP32MTT.03.B are fixed by inserting their metal tip into the ground. The connection cable must remain above the soil level.

### TP32MTT.03.A / TP32MTT.03.B

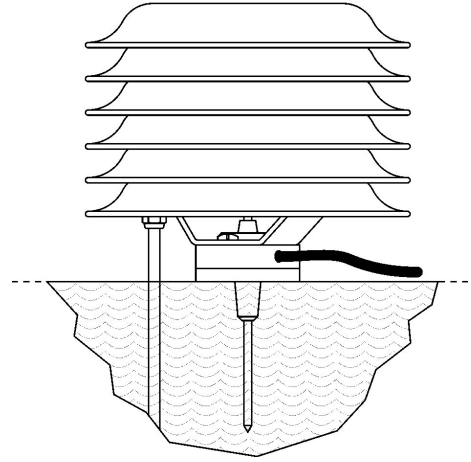

Installation of TP32MTT.03.A and TP32MTT.03.B on the ground

### CONNECTIONS TP32MTT.03.B

Wire color	Description	
Blue & Brown	Side 1	Upper (air) temperature sensor – Side 1
White & Red	Air	Upper (air) temperature sensor – Side 2
	Side 2	
Green & Yellow	Side 1	Lower (ground) temperature sensor – Side 1
	Ground	
Black & Grey	Side 2	Lower (ground) temperature sensor – Side 2
	Side 2	

### CONNECTIONS TP32MTT.03.A AND TP32MTT.03.C

Wire color	Description	
Blue & Brown	Side 1	Temperature sensor – Side 1
White & Red	Side 2	Temperature sensor – Side 2
	Side 2	

## ORDERING CODES

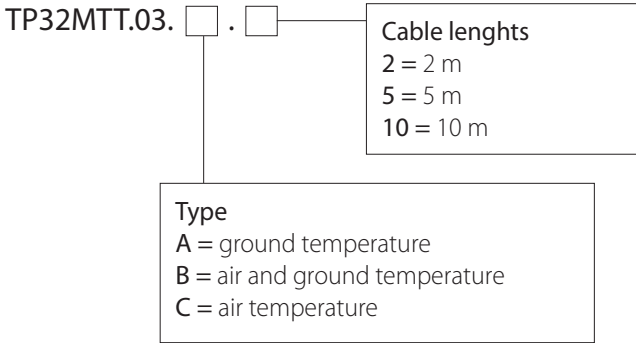

**TP32MTT.03.A:** Probe with 4-wire Pt100 sensor for the measurement of the soil temperature. With solar radiation screen. 4-pole cable terminated with open wires. Length of the cable 2, 5 or 10 m.

**TP32MTT.03.B:** Probe with two 4-wire Pt100 sensors for the measurement of air and soil temperature. With solar radiation screen. 8-pole cable terminated with open wires. Length of the cable 2, 5 or 10 m.

**TP32MTT.03.C:** Probe with 4-wire Pt100 sensor for the measurement of the air temperature. With solar radiation screen. 4-pole cable terminated with open wires. Length of the cable 2, 5 or 10 m.

**HD9007.T29.1:** Support bracket made of Anticorodal aluminium, powder coated, white. Includes screws for fixing on a flat support. For air temperature probe TP32MTT.03.C.

**HD9007.T29K:** Support bracket made of Anticorodal aluminium, powder coated, white. Complete with accessories for fixing on mast Ø 25...44 mm. For air temperature probe TP32MTT.03.C.

TP32MTT.03.A



TP32MTT.03.B



TP32MTT.03.C



## WARRANTY

The manufacturer is required to respond to the “factory warranty” only in those cases provided by Legislative Decree 6 September 2005 - n. 206. Each instrument is sold after rigorous inspections; if any manufacturing defect is found, it is necessary to contact the distributor where the instrument was purchased from. During the warranty period (24 months from the date of invoice) any manufacturing defects found will be repaired free of charge. Misuse, wear, neglect, lack or inefficient maintenance as well as theft and damage during transport are excluded. Warranty does not apply if changes, tampering or unauthorized repairs are made on the product. Solutions, probes, electrodes and microphones are not guaranteed as the improper use, even for a few minutes, may cause irreparable damages.

The manufacturer repairs the products that show defects of construction in accordance with the terms and conditions of warranty included in the manual of the product. For any dispute, the competent court is the Court of Padua. The Italian law and the “Convention on Contracts for the International Sales of Goods” apply.

## TECHNICAL INFORMATION

The quality level of our instruments is the result of the continuous product development. This may lead to differences between the information reported in the manual and the instrument you have purchased. We reserves the right to change technical specifications and dimensions to fit the product requirements without prior notice

## DISPOSAL INFORMATION



Electrical and electronic equipment marked with specific symbol in compliance with 2012/19/EU Directive must be disposed of separately from household waste. European users can hand them over to the dealer or to the manufacturer when purchasing a new electrical and electronic equipment, or to a WEEE collection point designated by local authorities. Illegal disposal is punished by law.

Disposing of electrical and electronic equipment separately from normal waste helps to preserve natural resources and allows materials to be recycled in an environmentally friendly way without risks to human health.

