

Leaf Wetness Sensor HD3901

DUAL-SENSITIVE SURFACE LEAF WETNESS SENSOR

INTRODUCTION

In agriculture and floriculture, precision and timely interventions are crucial for optimal plant health. The **HD3901 Leaf Wetness Sensor** is engineered to deliver exceptional accuracy in detecting condensation, replicating the thermodynamic behavior of real leaves. This essential tool provides invaluable data to help you make informed decisions about phytosanitary treatments, minimizing the risk of mold and fungal infections that can damage plants and crops.

With its advanced design and robust build, the HD3901 sensor ensures that your crops are monitored with the highest level of reliability, even in challenging environments. Whether you're cultivating in open fields or controlled greenhouse conditions, this sensor offers the data you need to protect your plants and maximize yields.

FEATURES

Accurate Leaf Wetness Detection

The HD3901 sensor simulates the behavior of a leaf with exceptional precision, providing accurate measurements of wetness caused by condensation.

Dual-Sensitive Surface

The sensor measures wetness on both the top and bottom surfaces of the leaf, accounting for the differing drying times of each side, and ensuring precise data collection.

Durability and Resistance

Built to withstand harsh environmental conditions, the sensor's surface is treated to resist atmospheric and chemical agents commonly found in pesticides, ensuring long-lasting performance.

Sealed and Protected

The electronic circuit is housed in a sealed plastic enclosure, offering reliable performance even in environments with high condensation.

Factory-Calibrated

The HD3901 comes pre-calibrated, saving you time and effort. No user calibration is required, ensuring out-of-the-box functionality.

CONFIGURATION & MEASUREMENT

Analog Output

The sensor delivers two 0.5 to 3 V analog outputs, providing a straightforward interface for integration into various monitoring systems.



THERMODYNAMIC PRECISION
Ensures reliable reproduction of the thermodynamic properties of a leaf



CAPACITIVE MEASUREMENT ACCURACY
Utilizes a capacitive measurement principle for precise detection of even the smallest drops of water



DUAL SENSITIVITY
Scratch-resistant coatings and minimal maintenance, ready for any environment



DURABILITY AND RESISTANCE
Exhibits high resistance to chemical and atmospheric agents



FIELD-READY INSTALLATION
Designed for field installation, offering IP67-rated protection against environmental elements

Technical specifications

Measuring principle	capacitive
Measuring range	0...100% of leaf area wetness
Accuracy	± 5%
Power supply	5...18 Vdc
Consumption	< 1 mA
Output	2 x analog 0.5...3 V
Operating temperature	-30...+60 °C
Dimensions	61 x 115 x 11 mm (excluding cable) width of the sensor 1.6 mm
Cable	4 poles ending with open wires, length 5 or 10 m depending on the model
Materials	Housing: PP Sensitive area: copper grid on glass epoxy substrate
Weight	100 g approx. (including the 5 m cable)
Protection degree	IP67

Dimensions

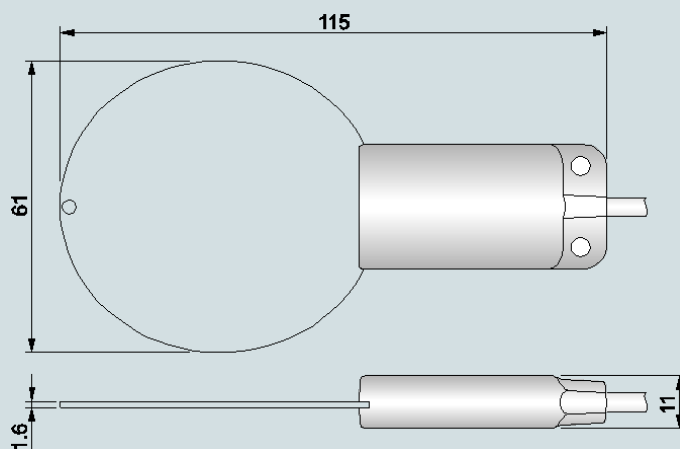

Ordering codes

HD3901.5	Leaf wetness sensor, 5 m cable
HD3901.10	Leaf wetness sensor, 10 m cable

Measuring principle

The HD3901 sensor features a sensitive surface equipped with two grid-shaped electrodes, designed to detect changes in the dielectric constant caused by the presence of water droplets. When water collects on the surface, the sensor identifies this change with remarkable precision, thanks to its advanced operating principle.

Unlike traditional sensors that rely on resistance or conductivity measurements and require larger water droplets to form between the electrodes, the HD3901 is capable of detecting even the smallest droplets. This superior sensitivity ensures more accurate detection in varying conditions, making it highly effective in agricultural applications.

The sensor's materials and white-colored sensitive surface have been carefully selected to mimic the thermal and radiative properties of a real leaf, enhancing its ability to replicate natural conditions. This allows for more reliable and realistic measurements of leaf wetness.

The sensor provides two 0.5 to 3 V analog outputs, corresponding to a wetness degree of 0% to 100%. This percentage indicates how much of the sensor's surface is covered by water, allowing for an accurate assessment of moisture levels across the entire sensitive area.

