

OPERATING MANUAL

HD2717 / HD2817

series

Temperature and
humidity transmitters,
ON/OFF regulators and
data loggers



EN
V2.0



Contents

1	Introduction	3
2	Technical specifications.....	4
3	Description	7
3.1	HD2717... models without display	7
3.2	HD2717... models with display.....	8
3.3	HD2817... models.....	10
4	Installation.....	12
4.1	Connections	13
4.2	Analog outputs	14
4.3	Relays.....	15
4.4	Serial connection	15
4.5	Probe connection	17
4.6	Date and time setting	17
5	Configuration menu in HD2717... models.....	18
6	Configuration menu in HD2817... models.....	23
7	Graph display (HD2817...)	29
8	RL1 and RL2 operating modes	30
9	Logging	31
10	Serial communication protocol	32
10.1	Printing data	32
10.2	List of the serial commands	33
11	Fault messages	37
12	Maintenance	38
12.1	Probe calibration.....	38
12.2	Probe replacement.....	38
12.3	Backup battery replacement.....	39
12.4	Cleaning.....	39
13	Safety instructions	40
14	Probes and accessories ordering codes	41

1 Introduction

HD2717... and **HD2817...** are temperature and humidity transmitters, ON/OFF regulators and data loggers with **interchangeable probe**.

The probe, factory calibrated and ready to use, is equipped with an internal module (SICRAM 2) which stores the probe calibration data, allowing interchangeability with virtually no interruption to the process.

Models with **horizontal probe** and models with connector for **vertical probe** or **probe with cable** are available.

In addition to the relative humidity (RH) measurement, the instruments calculate:

- Absolute Humidity (AH)
- Mixing Ratio (MR)
- Dew Point (Td)
- Wet bulb temperature (Tw)

All models feature analog outputs that can be configured independently as voltage or current, a multi-standard RS232/RS485 output and an auxiliary RS232 serial output. Several devices can be connected in a network through the RS485 connection. Optionally, configurable relay outputs (two operating relays and an alarm relay) are available.

The **data logging** function allows recording the detected measurements at regular intervals.

All **HD2817...** models have a graphic backlit LCD showing simultaneously three physical quantities in numerical form or the real-time graph of any of the detected quantities.

HD2717... models can be with or without custom LCD. The display shows the relative humidity or a calculated quantity on the main row, and the temperature on the secondary row.

The instrument configuration is permanently stored and the internal clock is protected against a power supply failure by a lithium battery.

Models

<p>HD2717 HD2817</p>	<p>.</p>	<p>Power supply "" = 90...240 Vac /24 = 24 Vac/dc</p> <p>Relay outputs 0 = no R = yes</p> <p>Display 0 = no (only HD2717...) D = yes (custom for HD2717..., graphic for HD2817...)</p> <p>Type of probe T = vertical probe or probe with cable TO = horizontal probe</p>
--	----------	--

2 Technical specifications

Temperature

Sensor	Pt100
Measuring range (*)	-50...+200 °C
Resolution	0.1 °C
Accuracy	±0.25 °C

Humidity

Sensor	Capacitive
Measuring range (*)	RH 0...100% AH 0...600 g/m ³ Td & Tw -50 ... +100 °C MR 0 ... 2000 g/kg of dry air
Resolution	0.1%RH
Accuracy	±1.5%RH (0...90%), ±2%RH (90...100%) @ T=15...35 °C ±(1.5 +1.5% of the measure)%RH @ T=remaining range For the accuracy of the humidity calculated quantities, see tables and graph below
Response time	3 min with filter @ 20 °C and 0.5 m/s

General specifications

Power supply	24 Vac/dc ± 10% or 90...240 Vac depending on model, 50...60 Hz Average consumption 3 W
Analog outputs	2 (HD2717...), 3 (HD2817...) Configurable 0...20 mA, 4...20 mA, 0...10 V or 2...10 V Outputs resolution 16 bits, accuracy ± 0.05% f.s. @ 20 °C
Relay outputs	Optional, 2 SPDT operating relays and 1 SPST normally open alarm relay 3 A / 250 Vac resistive load
Communication	RS232 and RS485
Memory	9000 samples in max. 256 sessions Circular management: if the memory is full, the new data overwrite the oldest data. All the parameters and the status of the outputs are stored. Storage interval configurable 1, 2, 5, 10, 20, 60 s / 2, 4 min
Internal clock	Real time with lithium backup battery. Accuracy ±1 min/month.
Display	Optional custom LCD in the models HD2717... Graphic (128 x 64 pixel) backlit LCD in the models HD2817...
Operating conditions	Instrument: -20...+60 °C / 0...90 %RH non-condensing Probe: static pressure max. 12 bar (16 bar for S.TC2.480.2, 8 bar for S481.2), max. temperature depends on version
Protection degree	IP 65
Storage temperature	-30...+80 °C
Material	ABS
Weight	600 g approx.

(*) Instrument measuring range; the probe may have more restrictive conditions depending on version.

Humidity calculated quantities

Dew point accuracy (°C) as a function of relative humidity

		Relative humidity (%)					
		10	30	50	70	90	100
Temperature (°C)	-20	0.92	0.49	0.30	0.22	--	--
	0	1.05	0.56	0.35	0.25	0.20	0.18
	20	1.18	0.75	0.45	0.34	0.27	0.23
	50	1.27	0.88	0.56	0.42	0.33	0.30
	100	1.30	1.17	0.76	0.58	0.47	0.42

Dew point (Td) accuracy as a function of temperature

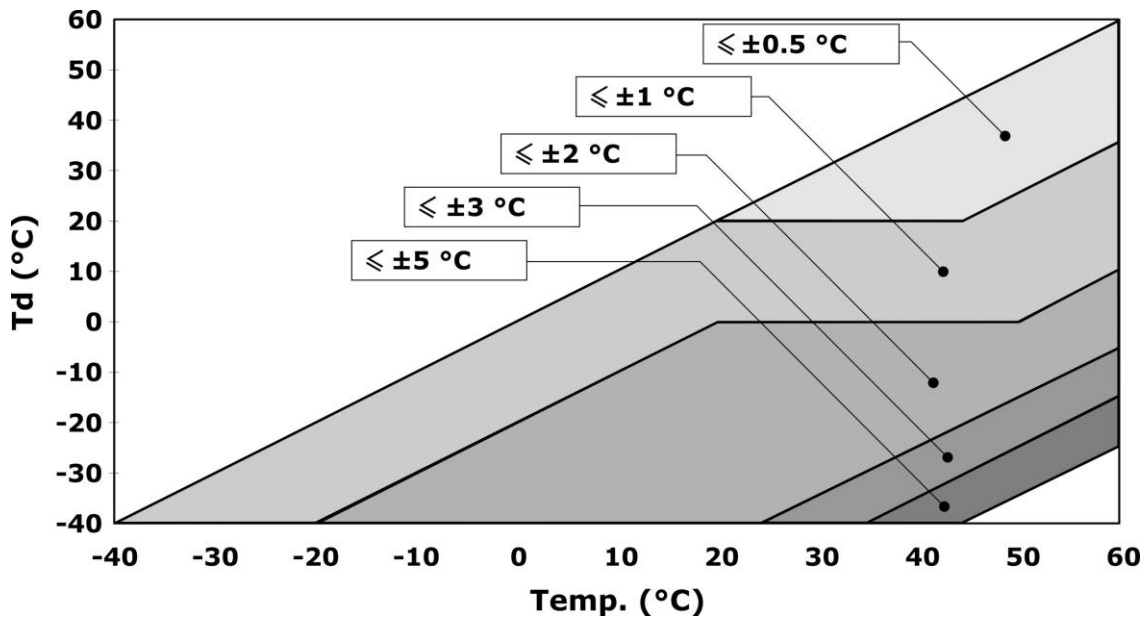

Absolute humidity accuracy (g/m³)

		Relative humidity (%)					
		10	30	50	70	90	100
Temperature (°C)	-20	0.015	0.020	0.025	0.030	---	---
	0	0.08	0.10	0.11	0.13	0.14	0.15
	20	0.28	0.33	0.40	0.44	0.50	0.55
	50	1.36	1.56	1.74	1.92	2.13	2.19
	100	9.37	10.2	11.3	12.3	13.2	13.5

Mixing ratio accuracy (g/kg)

		Relative humidity (%)					
		10	30	50	70	90	100
Temperatura (°C)	-20	0.014	0.017	0.020	0.024	---	---
	0	0.06	0.08	0.09	0.10	0.12	0.13
	20	0.24	0.29	0.34	0.39	0.44	0.45
	50	1.28	1.54	1.85	2.20	2.53	2.66
	100	12.5	23.2	46.2	136.0	---	---

Wet bulb temperature (°C)

		Relative humidity (%)					
		10	30	50	70	90	100
Temperature (°C)	-20	0.25	0.26	0.27	0.28	---	---
	0	0.29	0.32	0.35	0.37	0.4	0.412
	20	0.4	0.42	0.42	0.42	0.42	0.47
	50	0.98	0.89	0.84	0.82	0.81	0.8
	100	2.53	1.57	1.3	1.18	1.11	1.08

Dimensions (mm)

Vertical probe and probe with cable versions

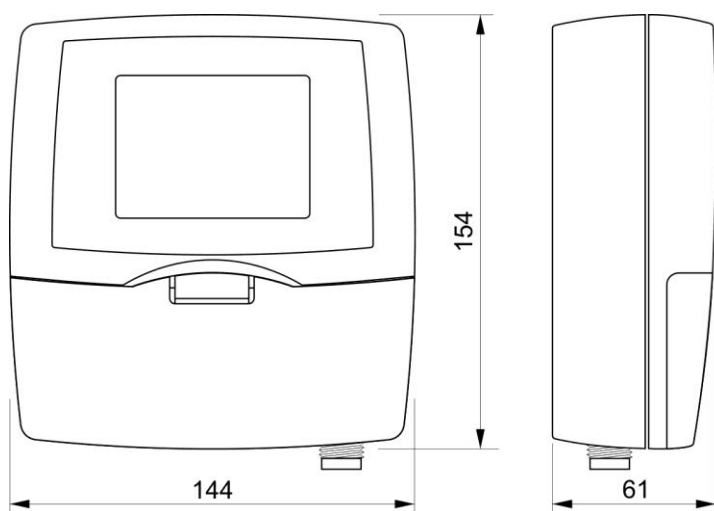

Horizontal probe versions

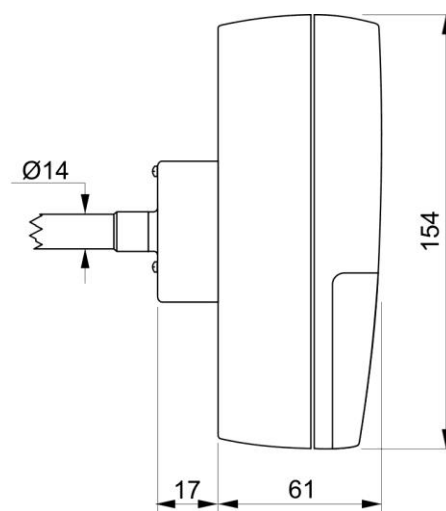

3 Description

3.1 HD2717... models without display



1. **AUX COM** key and LED
2. **PROBE CHANGE** key and LED
3. Cable glands (3x) for connecting power supply and outputs
4. M16 connector for connecting the probe (except horizontal probe versions)
5. Snap-locked terminal board cover

The LED next to AUX COM key lights up when the instrument is powered.

Functions of the keys

AUX COM	Activates the auxiliary serial port (COM AUX) for one minute, during which the LED next to the key blinks and the instrument waits for possible commands through the AUX COM serial port. If the instrument does not receive any command, after one minute it automatically returns to the configured serial port.
PROBE CHANGE	<p>Activates the "suspend" mode for one minute, during which the LED next to the key blinks, logging is stopped and the outputs (analog and relay) will remain in the state they were in when the key was pressed.</p> <p>Suspend mode is primarily used to replace the probe without interrupting the process. When normal operation is restored, the instrument reads the calibration parameters of the new probe and resume operation.</p> <p>If necessary, the suspend time can be extended by another minute by pressing PROBE CHANGE key again, or shortened by pressing and holding down the AUX COM key.</p>

3.2 HD2717... models with display



1. **UNIT** key
2. Arrow keys
3. LCD
4. Cable glands (3x) for connecting power supply and outputs
5. M16 connector for connecting the probe (except horizontal probe versions)
6. Snap-locked terminal board cover
7. **ESC** key
8. **ENTER / FUNC** key
9. **MENU** key

Display

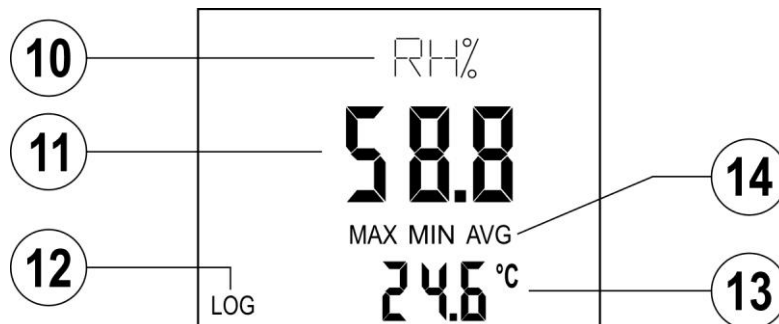

10. In measurement mode, indication of the physical quantity displayed in the main row. In menu, indication of the current menu item.
11. Main row: in measurement mode, the selected humidity quantity value is displayed.
12. LOG symbol: it indicates that the instrument is logging.
13. Secondary row: the temperature is displayed.
14. Indication of the type of statistic (MAX, MIN, or AVG) activated with the FUNC key.

Functions of the keys

UNIT	<p>Selects the humidity quantity to be displayed in the main row of the display and the temperature unit of measurement in the secondary row.</p> <p>By pressing the UNIT button once, the humidity quantity can be selected using the \wedge \vee arrows:</p> <ul style="list-style-type: none"> • RH%: relative humidity • G/m³: absolute humidity • G/kG: mixing ratio • Td: dew point • TW: wet bulb temperature <p>Pressing UNIT a second time confirms the displayed quantity and allows selecting the temperature unit (°C or °F). Press UNIT again to confirm and return to measurement mode.</p>
Up/down arrow	<p>Selects an item from a list or increases/decreases the value of the selected parameter.</p>
ESC	<p>In menu, it moves up one level in the menu hierarchy (canceling any unconfirmed changes).</p>
ENTER/FUNC	<p>In menu, it confirms the selected item.</p> <p>In measurement mode, it displays in sequence the MAX (maximum), MIN (minimum) and AVG (average) statistical functions.</p> <p>To reset the statistical functions and restart with a new calculation, press ENTER/FUNC until the message "CLR Func?" appears, then use the arrows to select YES and confirm with ENTER.</p>
MENU	<p>Enters the menu.</p> <p>Pressed inside the menu, the instrument returns directly to measuring mode.</p>

3.3 HD2817... models



1. **Vertical ZOOM** key
2. **Horizontal ZOOM** key
3. Arrow keys
4. LCD
5. Cable glands (3x) for connecting power supply and outputs
6. M16 connector for connecting the probe (except horizontal probe versions)
7. Snap-locked terminal board cover
8. **UNIT** key
9. **ESC** key
10. **ENTER / FUNC** key
11. **MENU** key

Display

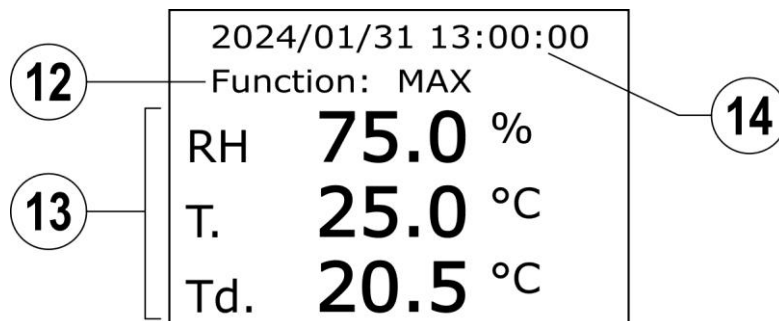

12. Auxiliary indications: e.g., the type of statistic (MAX, MIN, or AVG) activated with the FUNC key.
13. In measurement mode, the values of the three physical quantities associated with the analog outputs A1, A2 and A3 are displayed.
14. Date and time.

Functions of the keys

Vertical and horizontal ZOOM	In graph mode, they zoom in or out on the vertical and horizontal axes of the displayed graph.
Up/down arrow	Selects an item from a list or increases/decreases the value of the selected parameter.
UNIT	Selects the temperature unit of measurement (°C or °F). In graph mode, it selects the physical quantity.
ESC	In menu, it moves up one level in the menu hierarchy (canceling any unconfirmed changes).
ENTER/FUNC	In menu, it confirms the selected item. In measurement mode, it displays in sequence the MAX (maximum), MIN (minimum) and AVG (average) statistical functions. To reset the statistical functions and restart with a new calculation, press ENTER/FUNC until the message "CLR Func?" appears, then use the arrows to select YES and confirm with ENTER.
MENU	Enters the menu. Pressed inside the menu, the instrument returns directly to measuring mode.

4 Installation

The instrument should be installed indoor.

The instrument has a wall-mounting plate. To separate the plate from the instrument bottom, open the two front covers to access the terminal board. Unscrew the two screws shown in the following figure and pull the instrument toward yourself.

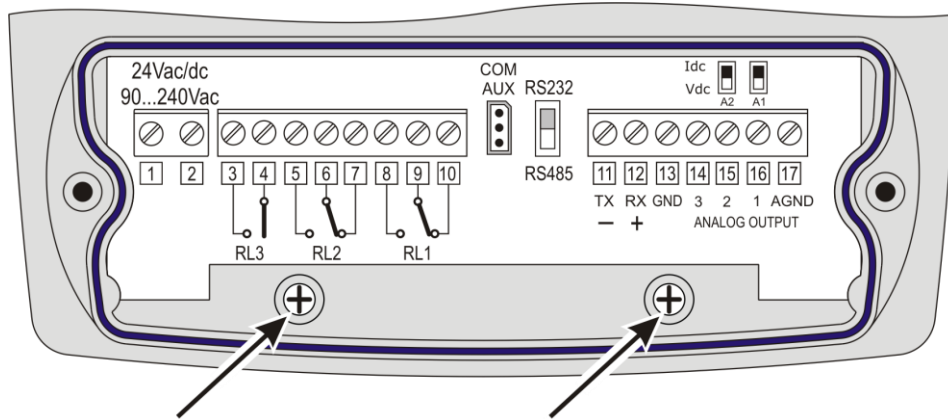

Fix the plate to the wall. The plate has 4 holes $\varnothing 4.5$ mm with 90 mm horizontal centre distance and 110 mm vertical centre distance.

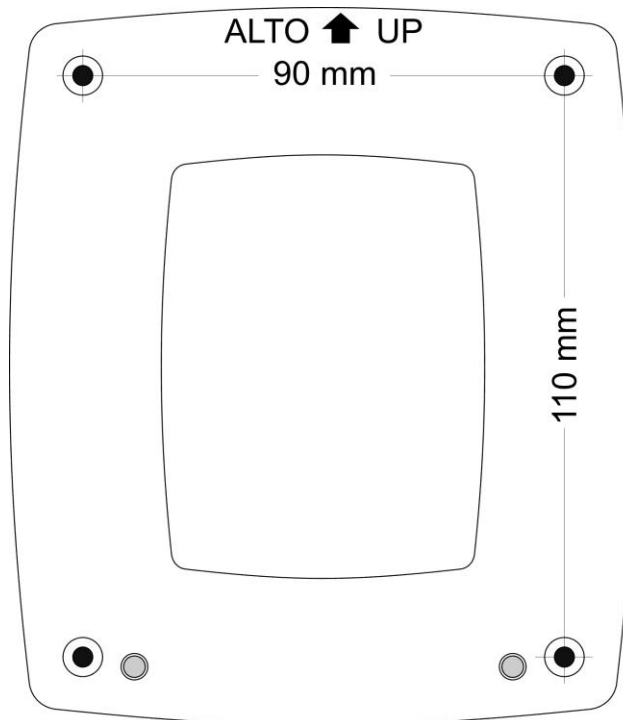

Once the plate is fixed, attached the instrument through the slot indicated by the arrow and fasten the two screws in the terminal board.

4.1 Connections

The terminal board is located in the lower part of the instrument, protected by two covers: the first external, snap-locked, the second internal, fixed with two screws.

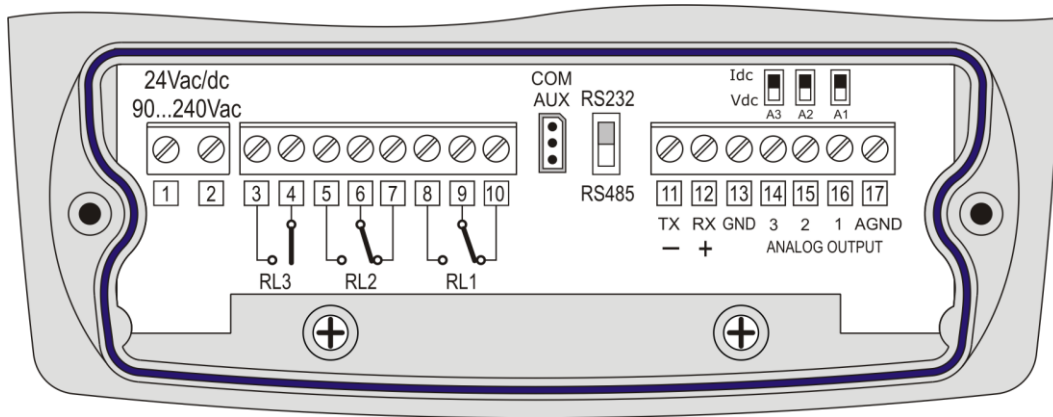

Terminals	Function		
1 – 2	Power supply 24 Vac/dc ± 10% or 90...240 Vac depending on model		
3 – 4	Alarm relay RL3 (if available in the model)		
5 – 6 – 7	Operating relay RL2 (if available in the model)		
8 – 9 – 10	Operating relay RL1 (if available in the model)		
11 – 12 – 13	RS232 or RS485 serial connection		
	Terminal	RS232 mode	RS485 mode
	11	To be connected to PC TX (pin 3 of DB9 connector)	To be connected to bus negative
	12	To be connected to PC RX (pin 2 of DB9 connector)	To be connected to bus positive
	13	To be connected to PC GND (pin 5 of DB9 connector)	To be connected to GND
14 – 15 – 16 – 17	Analog outputs		
	Terminal	Function	
	14	Output 3 positive (only HD2817...)	
	15	Output 2 positive	
	16	Output 1 positive	
	17	Analog outputs common negative	

COM AUX connector

Auxiliary RS232 serial port for the connection to a PC USB port via **CP27** cable (with integrated RS232/USB converter). Useful for temporarily connecting the instrument to a PC, for example to change the configuration, without having to disconnect and then reconnect the cables fixed to the terminal board.

4.2 Analog outputs

HD2717... models have two analog outputs (A1 and A2). HD2817... models have a third analog output (A3).

The outputs can be independently configured as current (Idc) or voltage (Vdc) via the dip switches A1, A2 and A3 located above the outputs positive terminals.

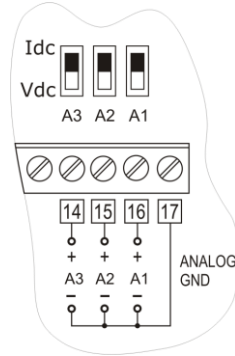

The load resistance varies according to the type of analog output set:

Analog output	Load resistance
0...10 V, 2...10 V	> 100 k Ω
0...20 mA, 4...20 mA	< 500 Ω

In the event of an anomaly in the measurement (detected measurement outside the measuring range), the output goes to a value 10% higher than the full scale: 11 V if the output is voltage, 22 mA if the output is current.

Offset of the outputs

The output can be set with offset (4...20 mA / 2...10 V) or without offset (0...20 mA / 0...10 Vdc) by means of the DeltaLog12 application software or the menu item:

- "ANL_OUT_MODE" in HD2717...
- "CONF. OUT → Output Analog 1-2-3 → Current/Voltage out" in HD2817...

The offset setting applies to all outputs.

Association of the quantities to the outputs

An output can be associated with any of the quantities measured and calculated by the instrument. To associate the quantities with the outputs and set the minimum and maximum values of the quantity corresponding to the minimum and maximum values of the output, use the DeltaLog12 application software or the menu item:

- "PWM_x_PAR_SET" (x=1, 2) in HD2717...
- "CONF. OUT → Output Analog 1-2-3 → Analog output x" (x=1, 2, 3) in HD2817...

In HD2817... models, the measurement of the quantities associated with the analog outputs A1, A2 and A3 appear respectively in the first, second and third measurement line of the display. In HD2717... models instead, the quantities displayed do not depend on which quantities are associated with the outputs.

4.3 Relays

In the models equipped with relays there are two ON/OFF operating relays (RL1 and RL2) and an alarm relay (RL3). The outputs are voltage-free.

RL1 and RL2 are SPDT (NO and NC contacts). RL3 is SPST (NO contact). When the instrument is not powered or is in "off-line" mode, the status of the contacts is that printed on the terminal block.

Relay	Contacts
RL1	8 – 9 NO contact 9 – 10 NC contact
RL2	5 – 6 NO contact 6 – 7 NC contact
RL3	3 – 4 NO contact

Configuration of the relays

RL1 and RL2 can be associated with any of the quantities measured and calculated by the instrument. To associate the quantities with the relays, set the intervention thresholds and the operation of the relays, use DeltaLog12 application software or the menu item:

- "RLx_PAR_SET" (x=1, 2, 3) in HD2717...
- "CONF. OUT → Output Relay → Relay x" (x=1, 2, 3) in HD2817...

The same menu items allow locking the relays in the fixed ON or OFF position to allow system maintenance operations.

4.4 Serial connection

The instrument is equipped with a main multi-standard RS232/RS485 serial communication port (terminals 11, 12 and 13) and an auxiliary RS232 serial port COM AUX.

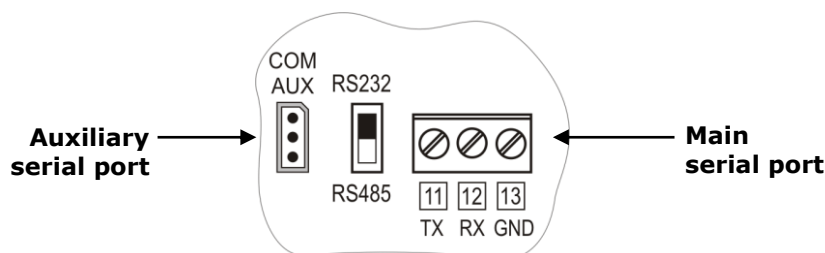

For fixed connection, the main port is used. The auxiliary port allows temporary connections, e.g. to change the configuration, without having to disconnect and then reconnect the cables fixed to the terminal board.

The main serial port and the auxiliary serial port are not active at the same time (the instrument supports only one communication channel at a time). The instrument is factory preconfigured with the auxiliary serial port active, to facilitate configuration operations. To select the main serial port or the auxiliary serial port, use the DeltaLog12 application software or the menu item:

- "COMM_PORT_SEL" in HD2717...
- "SERIAL" in HD2817...

The same menu items also allow selecting RS232 or RS485 for the main serial port. The dip switch located next to terminal 11 is for the main serial port and must be set to the same standard set in the menu for the main port, if enabled.

In HD2717... models without display, the auxiliary port can be activated (if not already active) for one minute by pressing the upper front button (the LED next to the button blinks to indicate that the COM AUX port is active).

The auxiliary serial port is always active for one minute when the instrument is turned on. After one minute, the instrument activates the set serial port.

RS232 connection

The diagram below shows the main serial port connection.

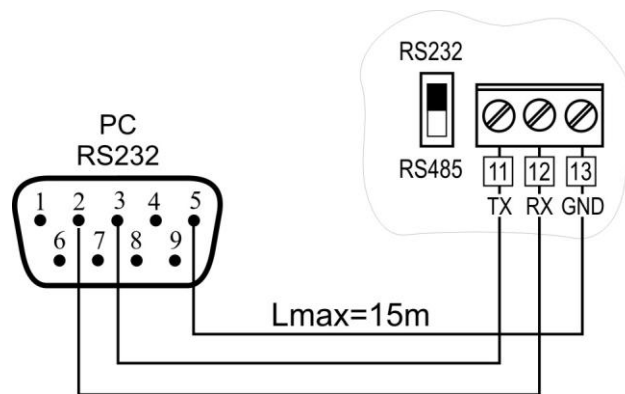

To connect the serial port to a PC USB port, use an RS232/USB converter.

The auxiliary serial port can be connected to a PC USB port via **CP27** cable (with integrated RS232/USB converter).

RS485 connection

To cover longer distances (up to 1200 m), the RS485 connection is used. This port allows creation of a network according to the diagram in the following figure.

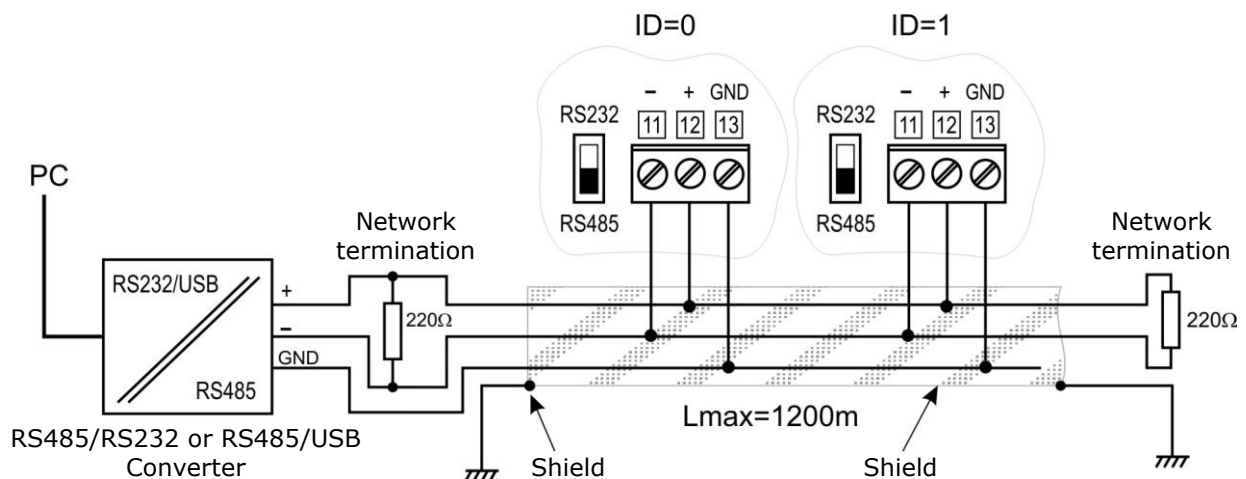

A network includes a maximum of **250** devices, connected through a shielded cable with a twisted pair for signals and a third wire for grounding.

Cable recommended characteristics: impedance 150 Ω, capacity <30pF/m, section >0.34 mm², resistance <110 Ω/km, wire diameter >0.64 mm.

If you need to connect more than 32 instruments, insert a signal repeater between a group and the next one. At the beginning and at the end of each segment you should apply the line terminator.

Each instrument must be identified by a **unique address**. The instrument is factory preconfigured with address 001. To change the address, use the DeltaLog12 application software or the menu item:

- "ADDR_SEL" in HD2717...
- "SERIAL → ADDRESS" in HD2817...

The address can be set from 1 to 250.

To manage the network and download the data, use the DeltaLog12 software.

4.5 Probe connection

In the models for vertical probe or probe with cable, connect the probe to the M16 connector in the lower part of the housing before powering the transmitter.

4.6 Date and time setting

When the instrument is powered up, the date and time check is requested for about one minute in the models with display.

HD2717... models

The "Time Date Set?" message is displayed. If the date and time are correct, press MENU to go directly to measurement mode; otherwise, use the \wedge \vee arrows to select "YES" and press ENTER: the year will appear; with the \wedge \vee arrows, change the value and confirm with ENTER to move on to the following fields: month, day, hour, minutes. The seconds restart from 00 when pressing ENTER to confirm the minutes. When finished, press MENU to return to measurement mode.

HD2817... models

The date and time will appear. If the date and time are correct, press MENU to go directly to measurement mode; otherwise, change the value (year) with the \wedge \vee arrows and confirm with ENTER to move on to the following fields: month, day, hour, minutes. The seconds restart from 00 when pressing ENTER to confirm the minutes. When finished, press MENU to return to measurement mode.

In both HD2717... and HD2817..., an internal backup battery ensures that the clock continues to run even when the power is off.

5 Configuration menu in HD2717... models

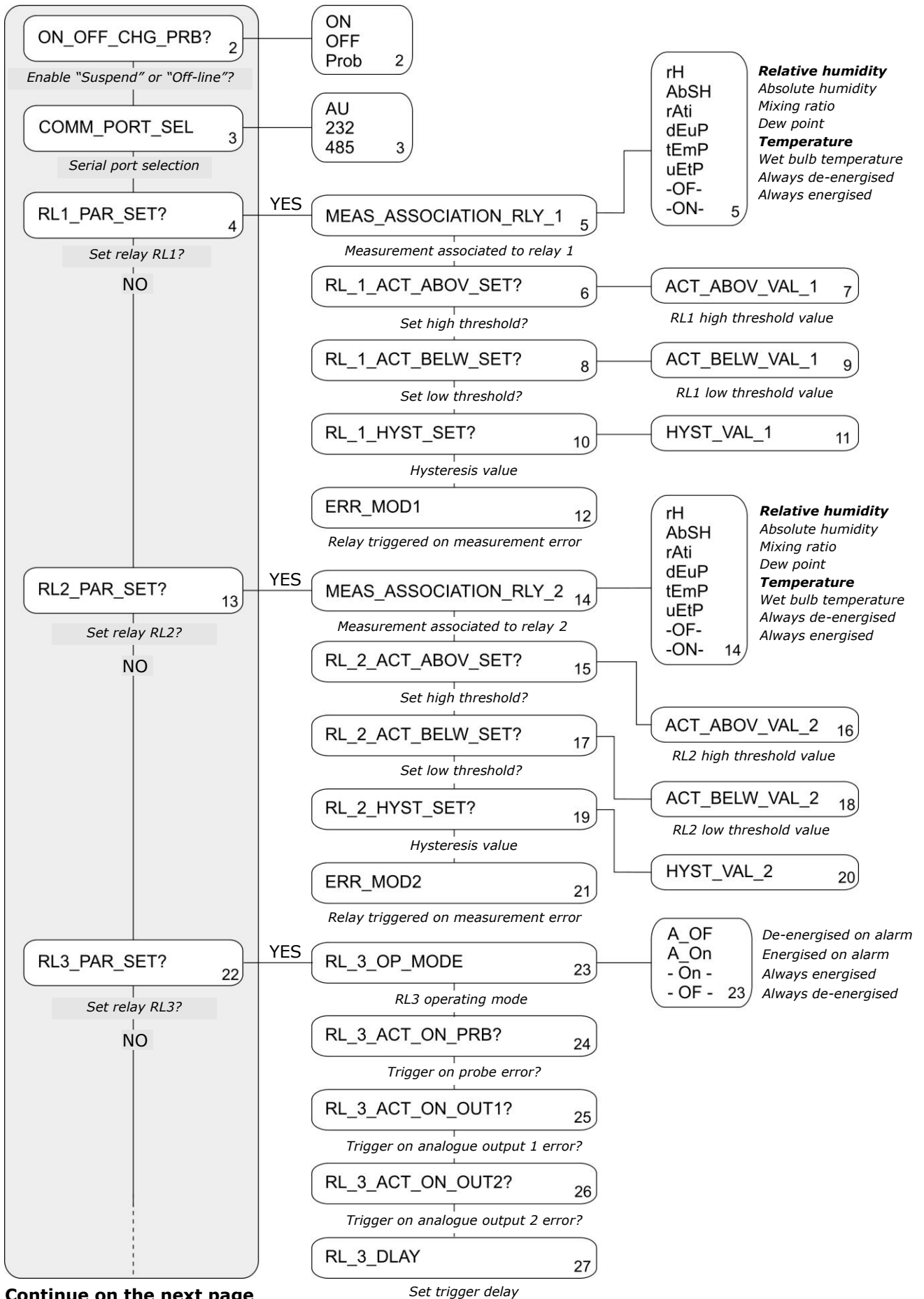

Continue on the next page

Continue from previous page

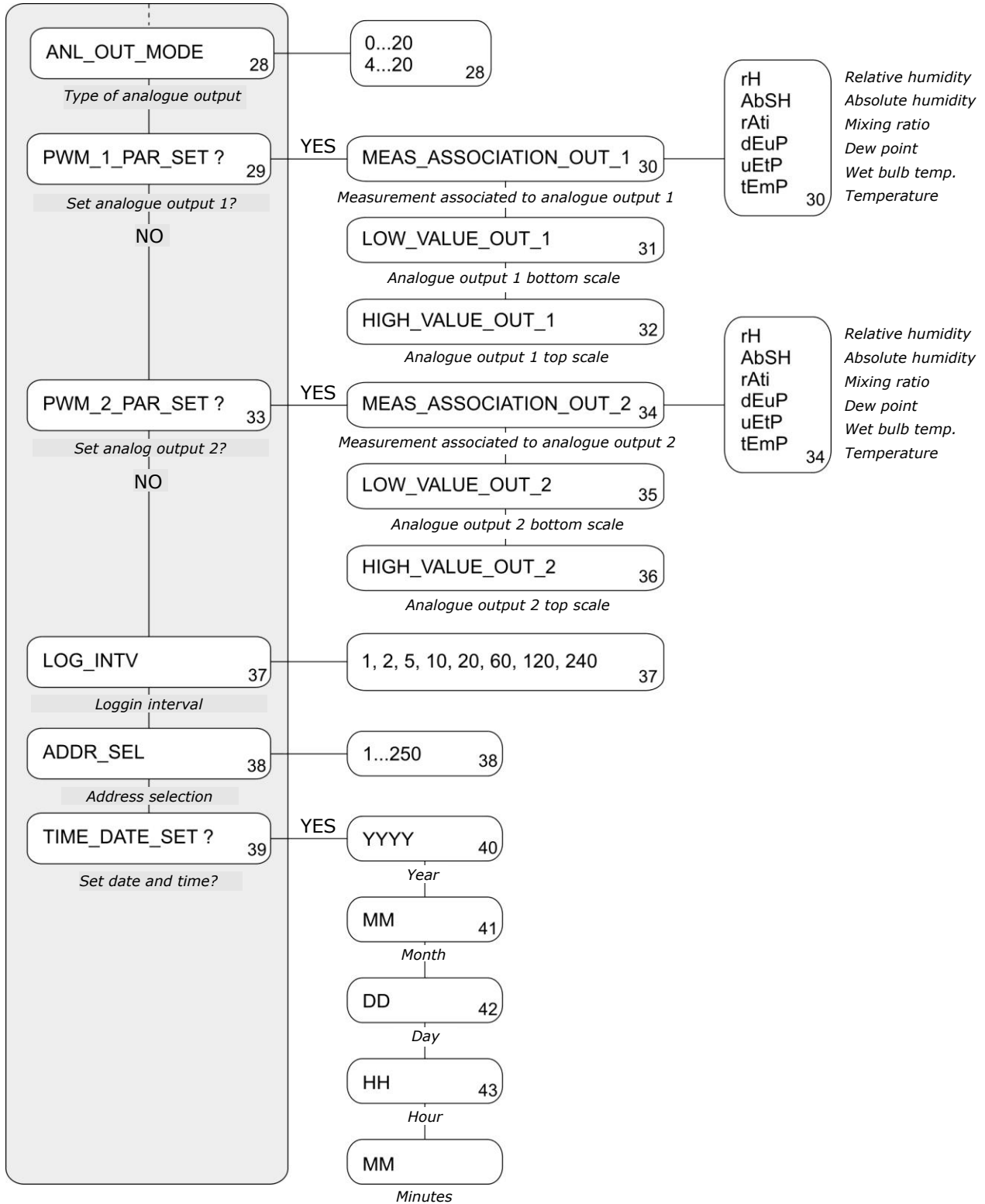

The menu screens are marked by an index on the lower right of the display to facilitate navigation among the various items.

To navigate within the menu, use the keys:

- Arrow keys (∧ ∨), to modify the value of a parameter.
- ENTER, to confirm a value and move to the next item.
- ESC, to go back one level (canceling any unconfirmed changes).
- MENU, to exit from any point in the menu and return directly to measurement.

The menu items are described below.

- **ON_OFF_CHG_PRB?**

Selection of operating mode.

- **ON:** normal operating mode (default).
- **OFF:** "off-line" mode; the relays are de-energized, the analog outputs are set to zero and logging is stopped; the display shows "OFF Line". To reactivate the instrument, hold down ENTER for a few seconds.
- **Prob:** activates the "suspend" mode for 60 s (a countdown appears on display), during which the outputs (analog and relay) will remain in the state they were in when the ENTER key was pressed, and the probe can be replaced. The time can be extended by another 60 s by pressing the up arrow. The other keys, except the ^ arrow and ENTER, reduce the remaining time to 3 s.

- **COMM_PORT_SEL**

Selection of the serial port to be used.

- **AU:** RS232 COM AUX (default).
- **232:** main RS232 (terminals 11 – 12 – 13).
- **485:** RS485 (terminals 11 – 12 – 13).

If 232 or 485 is selected, the dip switch located next to terminal 11 must be set to the same standard set in the menu.

- **RL1_PAR_SET?** and **RL2_PAR_SET?**

Setting of RL1 and RL2 relays operating parameters. Select YES with the arrows ^ v and confirm with ENTER to enter the submenu.

- **MEAS_ASSOCIATION_RLY_x** (x=1, 2)

Physical quantity associated to the relay:

- **rH:** relative humidity (default for RL1)
- **AbSH:** absolute humidity
- **rAti:** mixing ratio
- **dEuP:** dew point
- **tEmP:** environment temperature (default for RL2)
- **uEtP:** wet bulb temperature
- **-OF-:** relay always de-energized (NC contact closed, NO contact open)
- **-ON-:** relay always energized (NC contact open, NO contact closed)

- **RL_x_ACT_ABOV_SET?** (x=1, 2)

Upper relay activation threshold. It is the threshold beyond which the relay switches from the de-energized to energized state: the normally closed contact opens and the normally open contact closes. Select NO (default) to disable the threshold, or YES to enable it and set its value (**ACT_ABOV_VAL_x**).

- **RL_x_ACT_BELW_SET?** (x=1, 2)

Lower relay activation threshold. It is the threshold below which the relay switches from the de-energized to energized state: the normally closed contact opens and the normally open contact closes. Select NO (default) to disable the threshold, or YES to enable it and set its value (**ACT_BELW_VAL_x**).

- **RL_x_HYST_SET?** (x=1, 2)

Hysteresis applied to both the lower and upper thresholds. Select NO to disable the threshold, or YES (default) to enable it and set its value (**HYST_VAL_x**).

- **ERR_MODx** (x=1, 2)

Relay behavior in the event of a measurement error (measured value outside the measuring range, probe faulty or disconnected). Select NO to de-energize the relay in the event of an error (default, the status of the contacts is that printed on the terminal block), or YES to energize the relay in the event of an error (the NO contact closes and the NC contact opens).

- **RL3_PAR_SET?**

Setting of RL3 alarm relay operating parameters Select YES with the arrows \wedge \vee and confirm with ENTER to enter the submenu.

- **RL_3_OP_MODE**

Relay operating mode.

- **A_OF**: the relay is normally energized (contact closed) and de-energizes in the event of an alarm (contact open).
- **A_On**: the relay is normally de-energized (contact open) and energizes in the event of an alarm (contact closed). Default mode.
- **-On-**: relay always energized (contact between terminals 3 and 4 closed).
- **-OF-**: relay always de-energized (contact between terminals 3 and 4 open).

- **RL_3_ACT_ON_PRB?**

Select NO to disable the alarm in the event of a measurement error (measured value outside the measuring range, probe faulty or disconnected) or YES (default) to enable it.

- **RL_3_ACT_ON_OUT1?**

Select NO to disable the alarm in the event of an error in analog output 1 (exceeding set limits) or YES (default) to enable it.

- **RL_3_ACT_ON_OUT2?**

Select NO to disable the alarm in the event of an error in analog output 2 (exceeding set limits) or YES (default) to enable it.

- **RL_3_DLAY**

Alarm delay time, in seconds (default 0).

- **ANL_OUT_MODE**

Setting of analog outputs offset (common to all outputs).

- **0-20**: the outputs are 0...20 mA for current and 0...10 V for voltage.
- **4-20**: the outputs are 4...20 mA for current and 2...10 V for voltage. Default.

- **PWM_1_PAR_SET?** and **PWM_2_PAR_SET?**

Association of physical quantities with analog outputs and setting of output ranges. Select YES with the arrows \wedge \vee and confirm with ENTER to enter the submenu.

- **MEAS_ASSOCIATION_OUT_ x** (x=1, 2)

Physical quantity associated with the analog output:

- **rH**: relative humidity (default for A1)
- **AbSH**: absolute humidity
- **rAti**: mixing ratio
- **dEuP**: dew point
- **tEmP**: environment temperature (default for A2)
- **uEtP**: wet bulb temperature

- **LOW_VALUE_OUT_x** (x=1, 2)
Value of the physical quantity corresponding to the initial scale of the analog output (default 0.0 for all outputs).
- **HIGH_VALUE_OUT_x** (x=1, 2)
Value of the physical quantity corresponding to the full scale of the analog output (default 100.0 for all outputs).
- **LOG_INTV**
Setting of the logging interval in seconds: 1 (default), 2, 5, 10, 20, 60, 120 (2 minutes), 240 (4 minutes).
- **ADDR_SEL**
Setting of the network instrument address (1...250, default 1).
- **TIME_DATE_SET?**
Setting of instrument date and time, in the sequence year, month, day, hour and minutes. The seconds start from zero when pressing ENTER to confirm the minutes.

6 Configuration menu in HD2817... models

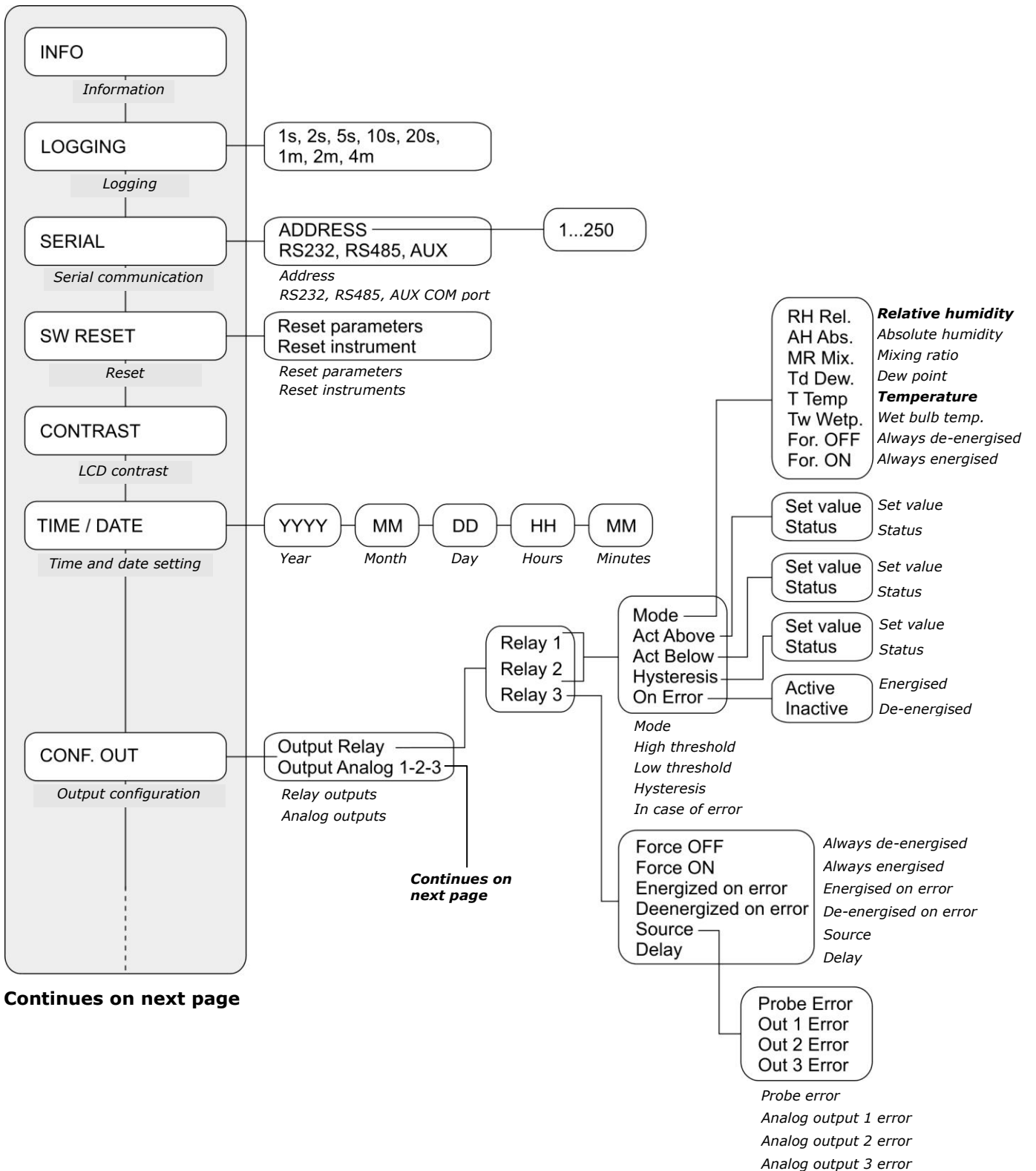

Continues on next page

Continues on next page

Continues from previous page

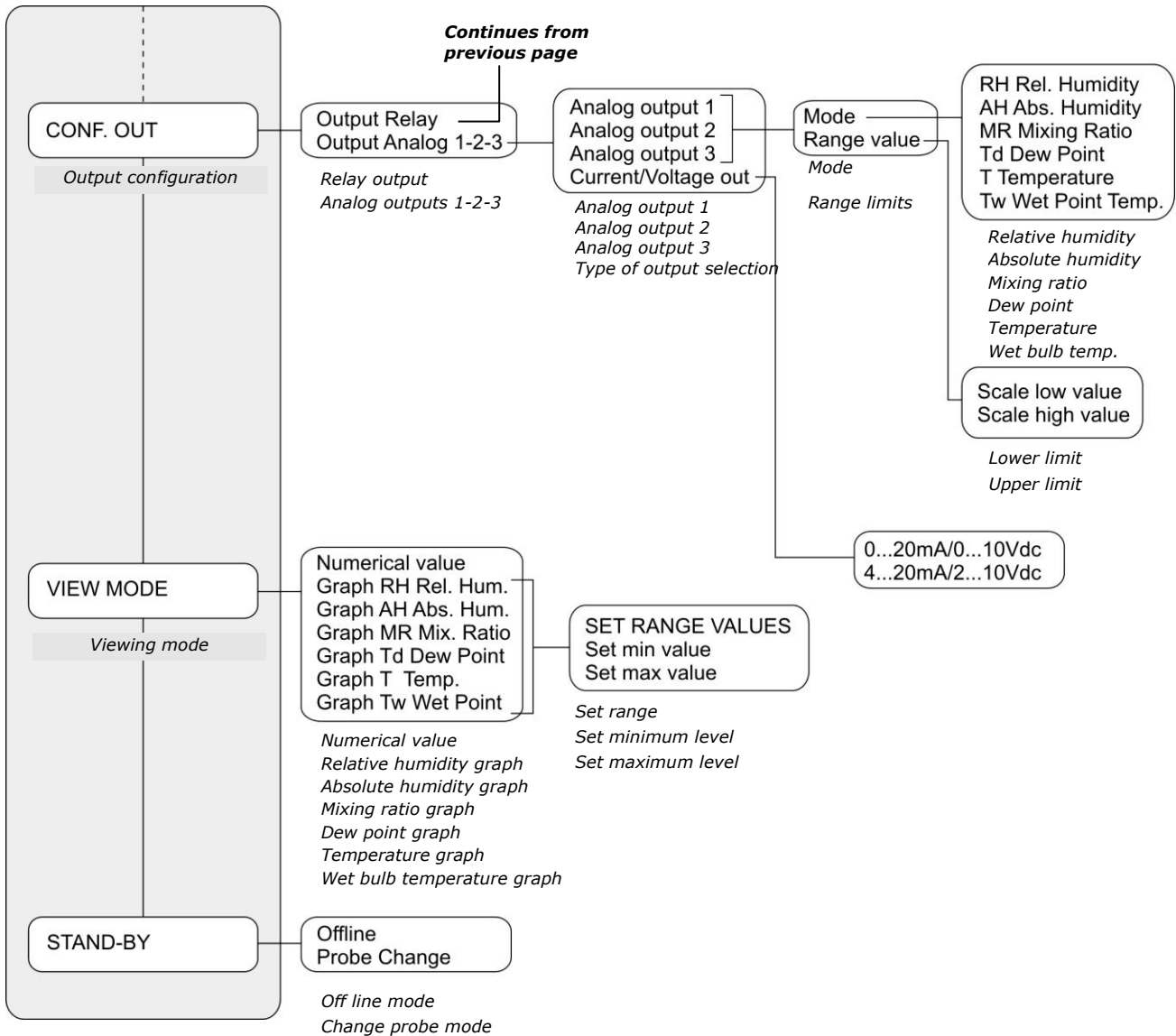

To navigate within the menu, use the keys:

- Arrow keys (∧ ∨), to select an item from a list or modify the value of a parameter.
- ENTER, to confirm the selection.
- ESC, to go back one level (canceling any unconfirmed changes).
- MENU, to exit from any point in the menu and return directly to measurement.

The menu items are described below.

• **INFO**

User ID, model, firmware version and date, instrument and probe serial number, calibration date, ...

The User ID is a code to identify the instrument and appears in the printouts and in the stored data. It can be changed via DeltaLog12 software.

• **LOGGING**

Setting of the logging interval: 1 (default), 2, 5, 10, 20, 60 seconds, 2 and 4 minutes.

- **SERIAL**

Setting of the network instrument address (1...250, default 1) and selection of the serial port to be used: **RS232** (main, terminals 11 – 12 – 13), **RS485**, **AUX** (default).

SERIAL
ADDRESS 001
* RS232
RS485
AUX
<UP> <DOWN> select
<ENTER> confirm
<ESC> exit

To change the address, select ADDRESS with the arrows \wedge \vee and confirm with ENTER: the parameter blinks; change the value with the arrows \wedge \vee and confirm with ENTER.

To set a serial port, select it with the arrows \wedge \vee and confirm with ENTER: an asterisk will appear next to the enabled port.

If RS232 or RS485 is selected, the dip switch located next to terminal 11 must be set to the same standard set in the menu.

- **SW RESET**

- **Reset parameters:** restores the default values for all parameters. Date/time and data in memory are retained.
- **Reset instrument:** restarts the instrument without changing the settings.

- **CONTRAST**

Adjustment of the display contrast. Adjust the contrast with the arrows \wedge \vee and confirm with ENTER.

- **TIME / DATE**

Setting of instrument date and time, in the sequence year, month, day, hour and minutes. The seconds start from zero when pressing ENTER to confirm the minutes.

- **CONF. OUT**

Setting of relay and analog outputs.

- **Output Relay**

Relay configuration. The screen for selecting RL1, RL2, or RL3 appears.

- If **RL1** or **RL2** is selected, the following screen appears:

RELAY RL...
Mode: T Temp.
Act Above: 100.0 °C
Act Below: 25.0 °C
Hysteresis: 1.0 °C
On Error: Inactive
<UP> <DOWN> select
<ESC> exit/cancel

- **Mode**

Physical quantity associated to the relay:

- **RH Rel.:** relative humidity (default for RL1)
- **AH Abs.:** absolute humidity
- **MR Mix.:** mixing ratio
- **Td Dew:** dew point
- **T Temp.:** environment temperature (default for RL2)
- **Tw Wetp.:** wet bulb temperature
- **For. OFF:** relay always de-energized (NC contact closed, NO contact open)
- **For. ON:** relay always energized (NC contact open, NO contact closed)

The quantity currently associated with the relay is marked with an asterisk.

- **Act Above**

Upper relay activation threshold. It is the threshold beyond which the relay switches from the de-energized to energized state: the normally closed contact opens and the normally open contact closes.

- **Set value:** threshold value.
- **Status:** threshold disable (Inactive) or enable (Active).

- **Act Below**

Lower relay activation threshold. It is the threshold below which the relay switches from the de-energized to energized state: the normally closed contact opens and the normally open contact closes.

- **Set value:** threshold value.
- **Status:** threshold disable (Inactive) or enable (Active).

- **Hysteresis**

Hysteresis applied to both the lower and upper thresholds.

- **Set value:** hysteresis value.
- **Status:** hysteresis disable (Inactive) or enable (Active).

- **On Error**

Relay behavior in the event of a measurement error (measured value outside the measuring range, probe faulty or disconnected). Select "Inactive" to de-energize the relay in the event of an error (default, the status of the contacts is that printed on the terminal block), or "Active" to energize the relay in the event of an error (the NO contact closes and the NC contact opens).

➤ If **RL3** is selected, the following screen appears:

RELAY RL3
Force OFF
Force ON
* Energized on error
Deenergized on error
Source: Probe
Delay: 0 sec
<ESC> exit/cancel

The first four items are the possible operating modes of the alarm relay. The asterisk indicates the current operating mode. To change the mode, select it with the arrows \wedge \vee and confirm with ENTER.

- **Force OFF:** relay always de-energized (contact between terminals 3 and 4 open).
- **Force ON:** relay always energized (contact between terminals 3 and 4 closed).
- **Energized on error:** the relay is normally de-energized (contact open) and energizes in the event of an alarm (contact closed). Default mode.
- **Deenergized on error:** the relay is normally energized (contact closed) and de-energizes in the event of an alarm (contact open).

- **Source**

Selection of alarm conditions; multiple conditions can be selected (the selected conditions are marked with an asterisk):

- **Probe Error:** alarm in the event of a measurement error (measured value outside the measuring range, probe faulty or disconnected).
- **Out 1 Error:** alarm in the event of an error in analog output 1 (exceeding set limits).
- **Out 2 Error:** alarm in the event of an error in analog output 2 (exceeding set limits).
- **Out 3 Error:** alarm in the event of an error in analog output 3 (exceeding set limits).

To enable/disable a condition, select it with the arrows \wedge \vee and confirm with ENTER.

- **Delay**

Alarm delay time, in seconds (default 0).

- **Output Analog 1-2-3**

Analog outputs configuration. The screen for selecting output 1, 2, or 3 and setting the output offset appears (Current/Voltage out).

Selecting **Current/Voltage out**, the analog outputs offset (common to all outputs) can be set: **4...20mA/2...10Vdc** (default) or **0...20mA/0...10Vdc**. The current setting is marked with an asterisk.

Selecting one of the output, the following screen appears:

OUTPUT ...
Mode: T Temp. Range values
<UP> <DOWN> select <ENTER> confirm <ESC> exit/cancel

- **Mode**

Physical quantity associated to the output:

- **RH Rel. Humidity:** relative humidity (default for A1)
- **AH Abs. Humidity:** absolute humidity
- **MR Mixing Ratio:** mixing ratio
- **Td Dew Point:** dew point
- **T Temperature:** environment temperature (default for A2)
- **Tw Wet point temp.:** wet bulb temperature

The quantity currently associated with the output is marked with an asterisk.

- **Range values**

Value of the physical quantity corresponding to the initial and full scale of the output (default 0.0 and 100.0 for all outputs).

OUT 2 TEMPERATURE RANGE
Scale low value: 0.0 °C
Scale high value: 100.0 °C
<ENTER> select
<ESC> exit/cancel

Press ENTER to toggle between the two items: the selected item will blink. Use the arrows \wedge \vee to change it, and press ENTER to confirm the value and go to the other item. Press ESC to exit.

- **VIEW MODE**

Selection of what to display.

- **Numerical values:** display of measurements in numerical form (default)
- **Graph RH Rel. Hum.:** display of relative humidity graph
- **Graph AH Abs. Hum.:** display of absolute humidity graph
- **Graph SH Mix. Ratio:** display of mixing ratio graph
- **Graph Td Dew Point:** display of dew point graph
- **Graph T Temp.:** display of environment temperature graph
- **Graph T Wet point temp.:** display of wet bulb temperature graph

The current selection is marked with an asterisk.

Selecting a graph, the screen for setting the minimum and maximum values of the graph y-axis appears:

GRAPHS SET RANGE VALUES
Graph T Temp.
set min: 0.0 °C
set max: 100.0 °C
<ESC> exit

To change the values, press ENTER to select "set min" and use the arrows \wedge \vee to set the minimum value; press ENTER to move to "set max" and use the arrows to \wedge \vee set the maximum value. Press MENU to exit.

- **STAND-BY**

Manual control of outputs for maintenance activities.

- **Offline:** the relays are de-energized, the analog outputs are set to zero and logging is stopped; the display shows "*STAND BY - <ENTER> exit stand-by*". To reactivate the instrument, hold down ENTER for a few seconds.
- **Probe Change:** activates the "suspend" mode for 60 s (a countdown appears on display), during which the outputs (analog and relay) will remain in the state they were in when the ENTER key was pressed, and the probe can be replaced. The time can be extended by another 60 s by pressing the up arrow. The other keys, except the \wedge arrow and ENTER, reduce the remaining time to 3 s.

7 Graph display (HD2817...)

HD2817... models can display the real-time graph of any of the available quantities.

To select the quantity to display on the graph, use the "VIEW MODE" menu item. Alternatively, use the UNIT key to change the quantity displayed on the graph without entering the menu.

The graph represents a curve of average values: the display width is 96 pixel and each pixel is the average calculated over a period of time that depends on the set logging interval (MENU >> LOGGING), as shown in the following table.

Logging interval (s)	Samples per pixel	Interval shown on the display
1	20	30 minutes
2	40	1 hour
5	75	2 hours
10	150	4 hours
20	300	8 hours
60 (1 minute)	900	24 hours
120 (2 minutes)	1800	48 hours
240 (4 minutes)	7200	192 hours

Since it takes between 20 seconds and 2 hours (7,200 seconds) to plot a new point on the graph, the graph may appear to be frozen, leading to doubts that the instrument is "stuck." The asterisk in the upper right corner blinks to indicate that the instrument is operating properly.

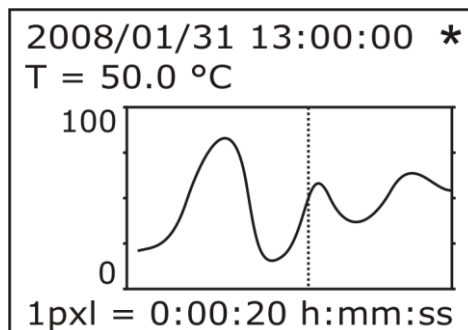

As time goes by, the graph shifts to the left, and the current measurement appears at the right vertical axis.

A cursor is superimposed on the graph; it is initially positioned at the right edge of the graph. To move the cursor, use the arrows \wedge \vee . The two lines at the top show the date/time and the measurement value at the position of the cursor.

The line at the bottom indicates the time interval represented by each pixel: min. 20 s, max. 2 hours (7200 seconds).

The horizontal ZOOM and vertical ZOOM keys expand the horizontal and vertical axes of the graph, respectively.

The horizontal zoom expands the pixel at the cursor location, displaying its samples. If there is space, adjacent pixels are also enlarged until the 96 pixels of the display are filled.

The first press of the vertical ZOOM key expands or contracts the vertical axis so that the entire graph is displayed at its full width. Subsequent presses of the key expand the graph to its maximum resolution.

8 RL1 and RL2 operating modes

If only the upper threshold (**Act above**) is enabled, the relay switches from de-energized to energized state when the measured value exceeds the set threshold (**A**), and de-energizes when the measured value falls below the threshold minus the hysteresis (**H**).

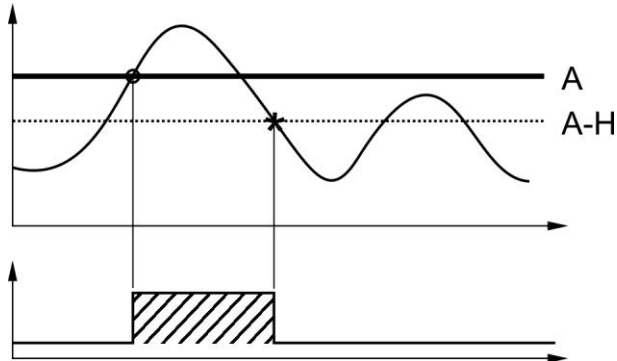

Relay activation/deactivation with only upper threshold enabled

If only the lower threshold (**Act below**) is enabled, the relay switches from de-energized to energized state when the measured value falls below the set threshold (**B**), and de-energizes when the measured value rises above the threshold plus the hysteresis (**H**).

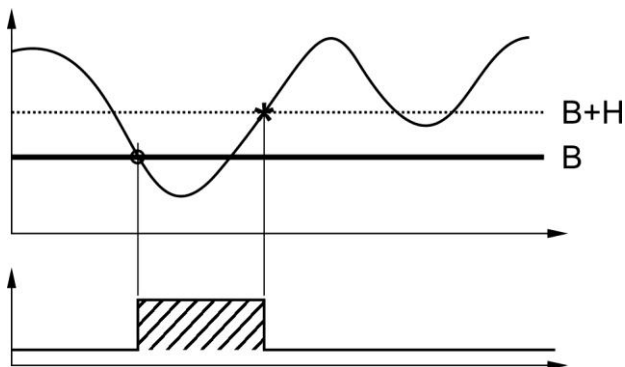

Relay activation/deactivation with only lower threshold enabled

If both upper and lower thresholds are enabled, the relay switches from de-energized to energized state when the measured value exceeds threshold **A** or falls below threshold **B** ($A > B$), and de-energizes when the measured value falls between **A-H** and **B+H**.

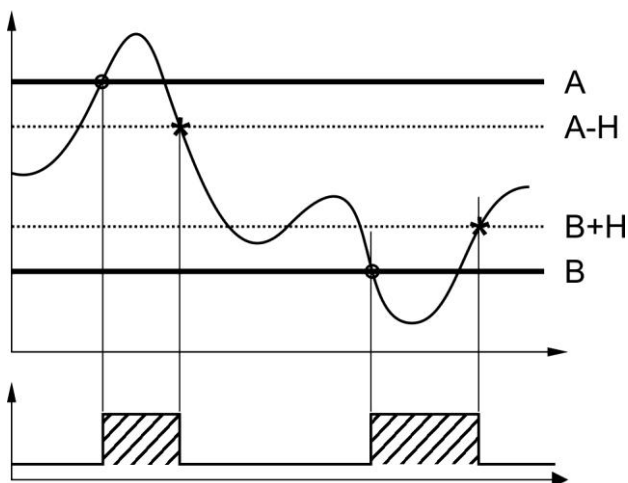

Relay activation/deactivation with both thresholds enabled

The hysteresis is the same for both thresholds.

The hysteresis can be disabled, but it is recommended to keep it active to prevent the relay from oscillating around the switching point.

The hysteresis width must be less than the difference between the two thresholds.

9 Logging

The logging is always active. The instrument can store 9000 samples. The memory is circular: once full, the most recent data overwrites the oldest ones. It is not possible to erase the memory.

Each sample stores date and time, temperature, relative humidity, absolute humidity, mixing ratio, dew point, wet bulb temperature, analog outputs value and state of the relays (if present).

The current logging session is stopped in the following cases:

- The log interval is changed
- The date and time are changed
- Suspend mode is activated
- Off-line mode is activated
- Power failure

The instrument automatically resumes logging, starting a new session, when the condition that caused the interruption ends (for example, after changing the logging interval).

The logging sessions are numbered from 0 to 255. After session 255, the count resets to 0.

Note: If the clock battery is low, the device may not be able to correctly number the session when logging resumes, and may start over from session zero, as well as store an incorrect date.

Each stored data represents the average of the measurements detected every second during the logging interval. Therefore, it is not the instantaneous value of the quantity at the end of the interval that is recorded, but the average over the entire interval. **The instrument performs a measurement every second.**

The state of each relay is stored as follows: "0" is stored if during the logging interval the relay is always de-energized, "1" if it is always energized, "V" if both conditions occur.

The stored data can be downloaded to a PC using DeltaLog12 software (see the software online help). During download, the instrument continues to log without interruption. To prevent data from being overwritten, the logging can be stopped using DeltaLog12 software. After the download, logging can be restarted using DeltaLog12 software.

The following table shows the logging duration based on the set interval, before the memory is filled and old data are overwritten:

Logging interval (s)	Storage capacity
1	2 hours and 30 minutes
2	5 hours
5	12 hours and 30 minutes
10	1 day and 1 hour
20	2 days and 6 hours
60	4 days and 4 hours
120	8 days and 8 hours
240	25 days

10 Serial communication protocol

The communication parameters are 9600 Baud, 8N2, flow control Xon-Xoff.

The serial command **KBH** allows changing the Baud rate to 57600. The change is not permanent: upon the next power on the Baud rate is restored to 9600.

Each command sent to the instrument must be preceded by the string **AxxZ**, where xx is the instrument address, and terminated by the Carriage Return (ASCII 0D). For example, A01ZP0 is the "Ping" to which the instrument with address 01 has to reply with the confirmation character.

In the communication via the COM AUX port, the instrument replies to any address. Therefore, the communication through such port can take place without having to set the instrument address; for example, by always using the string A00Z.

A confirmation character usually precedes the instrument reply strings (with some exceptions). The instrument response character is:

- **&** when in normal mode
- **\$** when in suspend mode
- **#** when in "off-line" mode

If the commands are not correctly addressed, no response is obtained.

Correctly addressed commands, but wrongly formulated or illegal, receive the response "?".

All commands requiring permanent changes of the instrument configuration (date/time, logging interval, etc.) must be preceded by the request to enable modifications **AxxZYU**, otherwise they will get the command rejection character ("?") in response. The editing permission expires after a few minutes of inactivity.

Multiple instruments on a network can be queried at a rate of one per second.

Warning: the instrument resets the internal peripheral device that handles serial communication after **two minutes** of inactivity on the line. Any commands sent during the reset are ignored; in that case, repeat the command. As the normal response latency does not exceed one second, the reiteration should occur after a two-second timeout.

10.1 Printing data

The "**K1**" command prints the instant measurements (not averaged over the logging interval). Printing is either single or continuous at regular intervals, depending on the index set using the **WAA**n command, as shown in the table below.

Index n	Printing interval in seconds
0	Single printing
1	1
2	2
3	5
4	10
5	20
6	60
7	120
8	240

Notes:

- The printing interval index set with WAA is not recorded in the permanent memory; the instrument, after a power cycle, restarts with the index 0, that is, single print.
- If there are multiple devices on a network (RS485), do not request continuous printing from multiple devices.

The reading of the data in memory from session number xxxx to session number yyyy included is performed with the **KRxxxx yyyy** command.

The **RM** command gives the current logging session. The most recently complete session, already available for printing, is the previous one. The system does not prevent the reading of the current session; however, since the instrument memory is arranged in circular mode (endless loop), the current page is partly formed by the last stored data and partly by the data stored during a previous session that have not yet been overwritten.

10.2 List of the serial commands

Command	Reply (*)	Description
DAyymmddhhmmss	&	Setting of instrument date/time in the format "yymmddhhmmss". The numbers must be entered as hexadecimal.
FA	&yymmddhhmmss	Instrument clock date/time. The numbers are in hexadecimal.
FC	&yymmddhhmmss	Factory calibration date. The numbers are in hexadecimal.
FS	&XXX	Instrument status. If it is logging, the first character is L; if it is in Print mode, the second character is P; if it is in error, the third character is E.
G0	HD27_17T_DR (<i>example</i>)	Instrument model
G1	M=Smart transmitter	Instrument type
G2	SN=xxxxxxxx	Instrument serial number
G3	Firm.Ver.=xx-yy	Firmware version
G4	Firm.Date=yyyy/mm/dd	Firmware date
G5	cal yyyy/mm/dd hh:mm:ss	Calibration date/time
G6	Probe=Sicram2 RH-Pt100	Type of probe
G7	Probe SN=11119999	Probe serial number
G8	F=aaaa/mm/gg hh:mm:ss; U=aaaa/mm/gg hh:mm:ss	Probe factory (F) and user (U) calibration date
GB	User ID=c...c	User code (it can be set with T2c...c)
GE	T; 0x03; 100.0; 15.5; 1.0; RH; 0x03; 80.5; 10.0; 1.0; 0xBF; 0 (<i>example</i>)	Configuration of relay 1, 2, 3. Associated quantity, operating mode (see table **), high threshold, low threshold and hysteresis are reported for RL1 and RL2. Status code (see table ***) and delay time are reported for RL3.

Command	Reply (*)	Description
GH	RH; 0.0; 100.0; T; 0.0; 100.0; Td; 0.0; 100.0 (example)	Configuration of analog outputs 1, 2, 3 (if available). Associated quantity and measuring range limits are reported for each output.
K0	&	Stop continuous data printing
K1	&	Data printing
K4	&	Start logging
K5	&	Stop logging
KBH		Change baud rate to 57600 (not permanent)
KBx		Reset baud rate to 9600 (x any except H)
Koff	#	Off-line mode activation
Kon	#	Exit from Off-line mode
KRxxxx yyyy	stampa	Printing of logging sessions from xxxx to yyyy
KSnn	&	Activation of "suspend" mode for nn seconds (nn=03...60)
P0	&	Ping
RAA		Printing interval
RAB		Logging interval
RM		Current session number
RX		With or without offset mode for analog outputs
RY		RS485 address
RZA		Humidity unit of measurement
RZB		Temperature unit of measurement
T2c...c	&	Setting of user code (max. 16 characters)
WAA _n	&	Setting of printing interval of index n [▶ table page 32]
WAB _n	&	Setting of logging interval of index n [▶ table page 32]
WB _n	&	Setting of quantity associated with relay 1: 0=always OFF, 1=RH, 2=AH, 3=MR, 4=Td, 5=temperature, 6=Tw, 9=always ON
WC _n	&	Setting of relay 1 operating mode (see table **)
WD _{nnn.n}	&	Relay 1 upper threshold
WE _{nnn.n}	&	Relay 1 lower threshold
WF _{nnn.n}	&	Relay 1 hysteresis
WG _n	&	Setting of quantity associated with relay 2: 0=always OFF, 1=RH, 2=AH, 3=MR, 4=Td, 5=temperature, 6=Tw, 9=always ON
WH _n	&	Setting of relay 2 operating mode (see table **)
WI _{nnn.n}	&	Relay 2 upper threshold
WJ _{nnn.n}	&	Relay 2 lower threshold
WK _{nnn.n}	&	Relay 2 hysteresis
WLn	&	Setting of relay 3 operating mode (see table ***)

Command	Reply (*)	Description
WMn	&	Setting of relay 3 alarm delay time, in seconds
WN000n	&	Setting of quantity associated with analog output 1: 1=RH, 2=AH, 3=MR, 4=Td, 5=temperature, 6=Tw
WOnnn.n	&	Value of the physical quantity corresponding to the initial scale of analog output 1
WPnnn.n	&	Value of the physical quantity corresponding to the full scale of analog output 1
WQ000n	&	Setting of quantity associated with analog output 2: 1=RH, 2=AH, 3=MR, 4=Td, 5=temperature, 6=Tw
WRnnn.n	&	Value of the physical quantity corresponding to the initial scale of analog output 2
WSnnn.n	&	Value of the physical quantity corresponding to the full scale of analog output 2
WTn (only HD2817...)	&	Setting of quantity associated with analog output 3: 0=RH, 1=AH, 2=MR, 3=Td, 4=temperature
WUnnn.n (only HD2817...)	&	Value of the physical quantity corresponding to the initial scale of analog output 3
WVnnn.n (only HD2817...)	&	Value of the physical quantity corresponding to the full scale of analog output 3
WWn	&	Setting of serial interface: 0=RS232, 1=RS485, 2=COM AUX
WXn	&	Setting of analog outputs offset: 0=without offset (0...20 mA or 0...10 V) 4=with offset (4...20 mA or 2...10 V)
WYnn	&	Setting of instrument address in hexadecimal: 01...FA (1...250)
WZBn	&	Setting of temperature unit of measurement: 0=°C, 1=°F
YU	USER CAL MODE ON	Enabling of configuration permanent changes. It expires after a few minutes of inactivity on serial port or if a wrong command is sent.
YX	CAL MODE OFF	Disabling of configuration permanent changes

(*) The reply & is replaced by \$ if in "suspend" mode, or # if in off-line mode.

(**) RL1 and RL2 operating modes

Bit								Hex	Description
7	6	5	4	3	2	1	0		
1	1	1	1	1	1	1	1	0xFF	Force energized
0	0	0	0	0	0	0	1	0x01	Only lower threshold active
0	0	0	0	0	0	1	0	0x02	Only upper threshold active
0	0	0	0	0	0	1	1	0x03	Both thresholds active
0	0	0	0	0	0	0	0	0x00	Idle
0	0	0	0	0	1	x	x	0x04	Hysteresis active
0	0	0	0	1	x	x	x	0x08	Energized in case of an error

(*) RL3 operating modes**

Bit								Description
7	6	5	4	3	2	1	0	
0	1	x	x	x	x	x	x	Force de-energized
1	1	x	x	x	x	x	x	Force energized
0	0	x	x	x	x	x	1	Normally de-energized, energized in case of sensor 1 error
1	0	x	x	x	x	x	1	Normally energized, de-energized in case of sensor 1 error
0	0	x	x	x	x	1	0	Normally de-energized, energized in case of sensor 2 error
1	0	x	x	x	x	1	0	Normally energized, de-energized in case of sensor 2 error
0	0	x	x	x	x	1	1	Normally de-energized, energized in case of sensor 1 or 2 error
1	0	x	x	x	x	1	1	Normally energized, de-energized in case of sensor 1 or 2 error
x	x	x	x	x	1	x	x	Error indication in case of analog output 1 outside the measuring range
x	x	x	x	1	x	x	x	Error indication in case of analog output 2 outside the measuring range
x	x	x	1	x	x	x	x	Error indication in case of analog output 3 outside the measuring range (only HD2817...)

11 Fault messages

The table lists the instrument fault messages (only models with display).

Message	Description
PROB ERR	Probe disconnected or not recognized. If the probe is disconnected, the "Prob comm lost" message scrolls in the upper display row.
CAL LOST	Program error: appears for a few seconds at startup. Contact the technical service.
OVER	Overflow: the measured value exceeds the measuring range.
ERR	It appears near the single measurement, it indicates a measurement error (faulty sensor, broken cable,...).

In HD2717... models without display, any anomaly is signaled by the two LEDs blinking simultaneously.

12 Maintenance

12.1 Probe calibration

The probe is factory calibrated and ready to use.

The relative humidity sensor can be recalibrated using the DeltaLog12 software (see the software online help).

There is no user calibration of the temperature sensor.

12.2 Probe replacement

The probe is interchangeable without the need for user calibration. To replace the probe, activate the “suspend” mode by means of:

- The PROBE CHANGE key in HD2717... models without display.
- The “ON_OFF_CHG_PRB → Prob” menu item in HD2717... models with display.
- The “STAND-BY → Probe change” menu item in HD2817... models.

During the “suspend” mode for (60 s), the outputs (analog and relay) will remain in the state remain in the status in which they are, allowing the probe to be replaced without interrupting the process.

If necessary, the suspension time can be extended by another 60 s by pressing the up arrow key in models with display, or the PROBE CHANGE key in models without display.

To replace the probe in models with horizontal probe, unscrew the 3 screws securing the probe holder module to the back of the instrument, then disconnect the probe from the instrument connector. Connect the new probe and secure the probe holder module with the 3 screws.

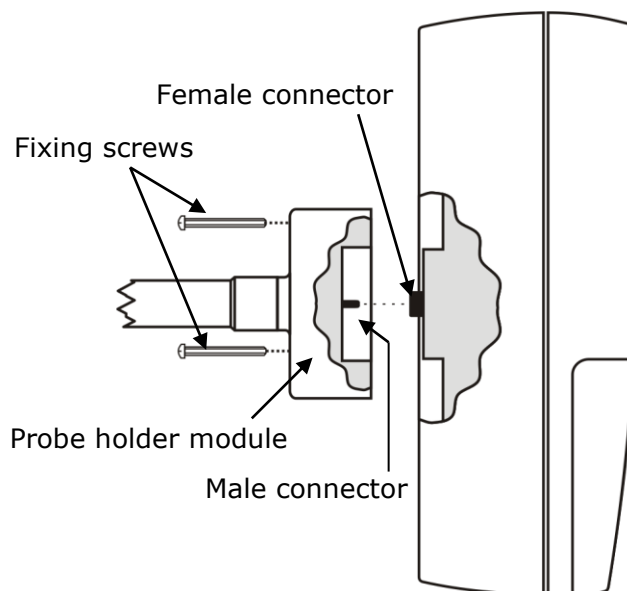

If desired, the suspension time can be shortened to 3 s by pressing any key, except up arrow \wedge and ENTER, in models with display, or by holding down the AUX COM key in models without display.

When the “suspend” mode ends, the instrument reads the calibration parameters of the new probe and resume operation, starting a new logging session.

Warning: for the collection of reliable data, the new probe should be thermally pre-conditioned in the measurement environment.

12.3 Backup battery replacement

The instrument is equipped with a backup battery that ensures the correct functioning of the clock in case of power failure.

Warning:

- there is no control on the battery charge status, so it is recommended to replace it at least every four years.
- before replacing the battery, disconnect the instrument power supply.

The battery is a 3 V lithium button cell (CR2032). The battery compartment is located on the back of the front panel.



Procedure

1. Separate the instrument from the mounting plate [► page 12].
2. Unscrew the 6 screws on the back.
3. Lift the front from the back making sure the flat cables that connect the instrument boards are not disconnected.
4. Extract the dead battery from its compartment.
5. Put the new battery in, **making sure the observe the correct polarity: the negative pole must face downwards.**
6. Close the instrument back with the 6 screws.
7. place the instrument back on the mounting plate.

12.4 Cleaning

In order to grant measurements high accuracy, it is necessary to clean the filter periodically.

To clean the filter, unscrew it from the probe body and wash it under running water with the help of a brush. Dry the filter and screw it back to the probe body.

Warning: after removing the filter, be careful not to touch the RH sensor with your hands, so as not to damage it irreparably.

If the filter is too dirty to be able to clean, it can be replaced with a new one.

Do not use aggressive cleaning agents or incompatible with the materials indicated in the technical specifications. For cleaning the housing, use a soft dry cloth or slightly dampened with clean water.

13 Safety instructions

The transmitter proper operation and operating safety can be ensured only in the climatic conditions specified in this manual and if all standard safety measures as well as the specific measures described in this manual are followed.

Do not use the instrument in places where there are:

- Corrosive or flammable gases.
- Direct vibrations or shocks to the instrument.
- High-intensity electromagnetic fields, static electricity.

User obligations

The transmitter operator shall follow the directives and regulations below that refer to the treatment of dangerous materials:

- EU directives on workplace safety.
- National law regulations on workplace safety.
- Accident prevention regulations.

14 Probes and accessories ordering codes

The transmitter is supplied with DeltaLog12 software, downloadable from the website.

Probe, PC connecting cable and fixing accessories must be ordered separately.

Temperature and relative humidity combined probes

S.TV	Vertical probe without cable. Stainless steel stem Ø14 mm, L=130 mm. P8 filter.
S.TC1.2	Probe with 2 m cable. Stainless steel stem Ø14 mm, L=135 mm. P7 filter. Max. 150 °C.
S.TC1.2HT	Probe with 2 m cable. Stainless steel stem Ø14 mm, L=135 mm. P6 filter. Max. 170 °C.
S.TC1.2P	Probe with 2 m cable. PBT stem Ø14 mm, L=135 mm. P7 filter. Max. 120 °C.
S.TC1.5	Probe with 5 m cable. Stainless steel stem Ø14 mm, L=135 mm. P7 filter. Max. 150 °C.
S.TC1.5HT	Probe with 5 m cable. Stainless steel stem Ø14 mm, L=135 mm. P6 filter. Max. 170 °C.
S.TC1.5P	Probe with 5 m cable. PBT stem Ø14 mm, L=135 mm. P7 filter. Max. 120 °C.
S.TC1.10	Probe with 10 m cable. Stainless steel stem Ø14 mm, L=135 mm. P7 filter. Max. 150 °C.
S.TC1.10HT	Probe with 10 m cable. Stainless steel stem Ø14 mm, L=135 mm. P6 filter. Max. 170 °C.
S.TC1.10P	Probe with 10 m cable. PBT stem Ø14 mm, L=135 mm. P7 filter. Max. 120 °C.
S.TC2.2	Probe with 2 m cable. Stainless steel stem Ø14 mm, L=335 mm. P7 filter. Max. 150 °C.
S.TC2.2HT	Probe with 2 m cable. Stainless steel stem Ø14 mm, L=335 mm. P6 filter. Max. 170 °C.
S.TC2.2P	Probe with 2 m cable. PBT stem Ø14 mm, L=335 mm. P7 filter. Max. 120 °C.
S.TC2.5	Probe with 5 m cable. Stainless steel stem Ø14 mm, L=335 mm. P7 filter. Max. 150 °C.
S.TC2.5HT	Probe with 5 m cable. Stainless steel stem Ø14 mm, L=335 mm. P6 filter. Max. 170 °C.
S.TC2.5P	Probe with 5 m cable. PBT stem Ø14 mm, L=335 mm. P7 filter. Max. 120 °C.
S.TC2.10	Probe with 10 m cable. Stainless steel stem Ø14 mm, L=335 mm. P7 filter. Max. 150 °C.
S.TC2.10HT	Probe with 10 m cable. Stainless steel stem Ø14 mm, L=335 mm. P6 filter. Max. 170 °C.
S.TC2.10P	Probe with 10 m cable. PBT stem Ø14 mm, L=335 mm. P7 filter. Max. 120 °C.

- S.TO1** Horizontal probe. Stainless steel stem Ø14 mm, L=135 mm. P7 filter. Max. 150 °C.
- S.TO2** Horizontal probe. Stainless steel stem Ø14 mm, L=335 mm. P7 filter. Max. 150 °C.
- S.TC2.480.2** Probe with 2 m cable for the measurement of compressed air in pipes. In stainless steel. P6 filter. Temperature measuring range -40...+60 °C, -40...+60 °C Td. Three 1/4" quick couplings. Max. pressure 16 bar.
- S.481.2** Probe with 2 m cable for pipes. G 1/2" threading. In stainless steel. P6 filter. Temperature measuring range -40...+60 °C, -40...+60 °C Td. Operating pressure -1...8 bar.

Fixing accessories

- HD9008.21.1** Wall-mount flange with support for vertical installation of S.TC... probes. Distance from the wall 250 mm.
- HD9008.21.2** Wall-mount flange with support for vertical installation of S.TC... probes. Distance from the wall 125 mm.
- HD9008.31** Wall flange with cable gland to fix Ø14 mm probes.
- PG16** AISI304 cable gland to fix Ø14 mm probes. G 1/2", L=8 mm thread.

PC connecting cables

- CP27** Cable for connecting the COM AUX port to the PC, with built-in RS232/USB converter. 3-pole connector on transmitter side and A-type USB connector on PC side.

Saturated solutions

- HD75** Saturated solution for checking the Relative Humidity sensor at 75% RH. Includes screw adaptor for Ø14 mm probes.
- HD33** Saturated solution for checking the Relative Humidity sensor at 33% RH. Includes screw adaptor for Ø14 mm probes.
- HD11** Saturated solution for checking the Relative Humidity sensor at 11% RH. Includes screw adaptor for Ø14 mm probes.

Spare parts

- P6** 10 µm sintered stainless steel filter.
- P7** 20 µm PTFE filter.
- P8** Filter in PBT with 10 µm stainless steel grid.

WARRANTY

The manufacturer is required to respond to the "factory warranty" only in those cases provided by Legislative Decree 6 September 2005 - n. 206. Each instrument is sold after rigorous inspections; if any manufacturing defect is found, it is necessary to contact the distributor where the instrument was purchased from. During the warranty period (24 months from the date of invoice) any manufacturing defects found will be repaired free of charge. Misuse, wear, neglect, lack or inefficient maintenance as well as theft and damage during transport are excluded. Warranty does not apply if changes, tampering or unauthorized repairs are made on the product. Solutions, probes, electrodes and microphones are not guaranteed as the improper use, even for a few minutes, may cause irreparable damages.

The manufacturer repairs the products that show defects of construction in accordance with the terms and conditions of warranty included in the manual of the product. For any dispute, the competent court is the Court of Padua. The Italian law and the "Convention on Contracts for the International Sales of Goods" apply.

TECHNICAL INFORMATION

The quality level of our instruments is the result of the continuous product development. This may lead to differences between the information reported in the manual and the instrument you have purchased.

We reserve the right to change technical specifications and dimensions to fit the product requirements without prior notice.

DISPOSAL INFORMATION

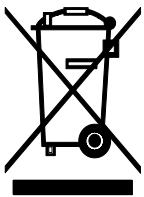

Electrical and electronic equipment marked with specific symbol in compliance with 2012/19/EU Directive must be disposed of separately from household waste. European users can hand them over to the dealer or to the manufacturer when purchasing a new electrical and electronic equipment, or to a WEEE collection point designated by local authorities. Illegal disposal is punished by law.

Disposing of electrical and electronic equipment separately from normal waste helps to preserve natural resources and allows materials to be recycled in an environmentally friendly way without risks to human health.



senseca.com



Senseca Italy S.r.l.
Via Marconi, 5
35030 Selvazzano Dentro (PD)
ITALY
info@senseca.com

