

OPERATING MANUAL

VUP12

Ventilation and
heating unit

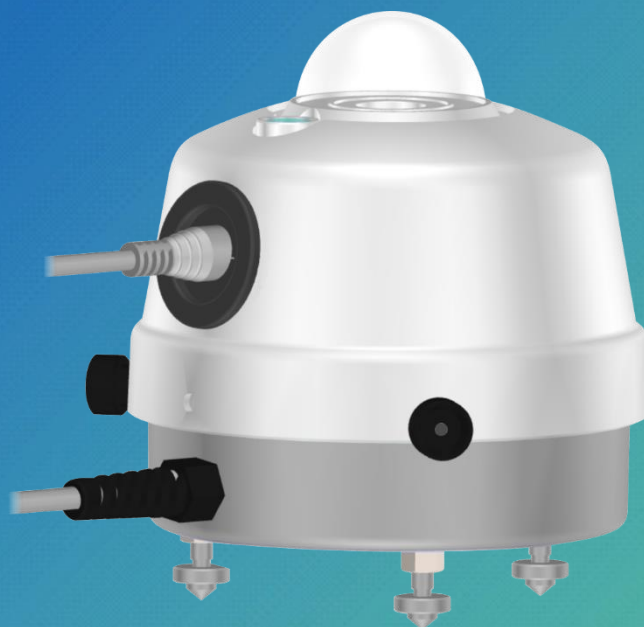

EN

V1.1



Contents

1	Introduction	3
2	Technical specifications.....	4
3	Installation.....	5
4	Use of ventilation and heating	7
5	Maintenance	8
6	Safety instructions	9

1 Introduction

The **VUP12** ventilation and heating unit allows increasing the accuracy of solar radiation measurements maintaining the operating temperature of the sensor uniform. Ventilation reduces the type "A" offset (present in pyranometers and pyrgeometers) due to cooling of the dome with respect to the sensor body.

It can be used outdoor in any weather condition and avoids the formation of dew and frost on the optical part of the sensor.

The use of ventilation and moderate heating prevents dew formation on the dome, especially in the early morning hours, allowing much more accurate measurements even in moderate climates.

The heating function can also be used in extreme environmental conditions, to avoid the formation of snow and ice on the sensor dome.

The unit is equipped with two independent heating circuits of equal power, which can be individually activated to better adapt the heating function to the climate of the installation site.

Supplied as standard with a fixed 5 m connection cable.

The unit is suitable for **LPS02...** and **LPS10...** series pyranometers and allows solar radiation measurements to be performed according to the recommendations of the following standards:

- **ISO/TR 9901**
- **IEC 61724-1**
- **"BSRN operations manual"**

Caution!

The unit contains parts that could be at high temperature (heater) and moving mechanical parts (fan).

Before performing installation and maintenance operations, disconnect the power supply and wait for the heater to cool down.

- The unit is not intended for use with sensors other than those indicated.
- Respect the power supply values indicated in the technical specifications and pay attention to the indicated polarities.
- Do not use extension cables.

Symbols:



Warning – hot surface

2 Technical specifications

Ventilation power supply	12 Vdc \pm 10% / 1.6 W
Heating power supply	12 Vdc \pm 10% 6 W (heating 1) + 6 W (heating 2)
Operating conditions	-40...+70 °C / 0...100 %RH Max. altitude 3000 m
Increase of air temperature with heating on	~2,2 °C with ventilation and both heating circuits on ~1,1 °C with ventilation and one heating circuit on
Cable length	5 m standard, ending with free wires
Protection degree	IP 54 IP 67 the internal electrical connection
Weight	0.6 kg approx. (excluding cable)

Dimensions (mm) and description

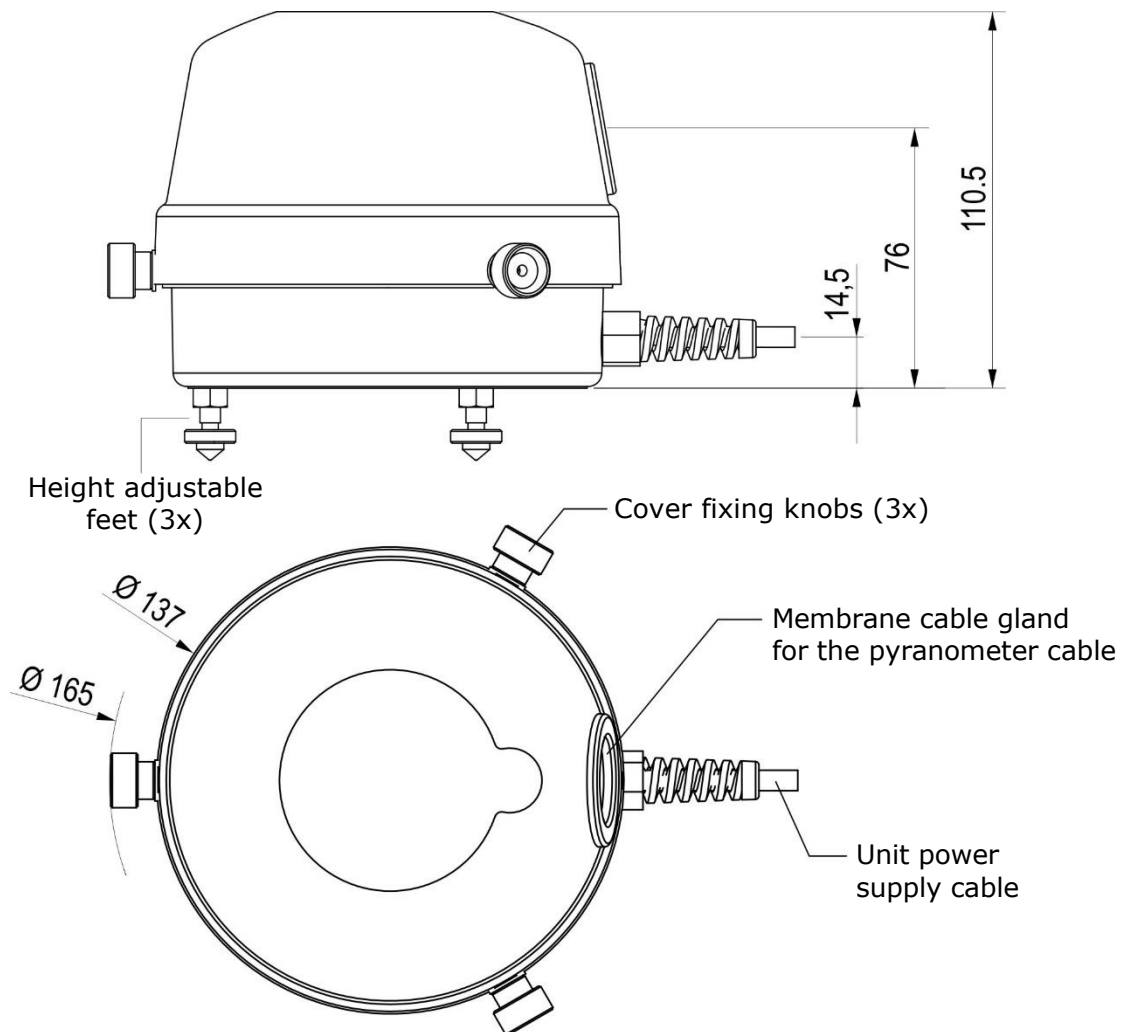

3 Installation

Fixing the pyranometer

If ordered together with the unit, the pyranometer is already installed inside the unit. If the unit has been ordered separately, to install the pyranometer:

- if present, remove the pyranometer shade disk and feet;

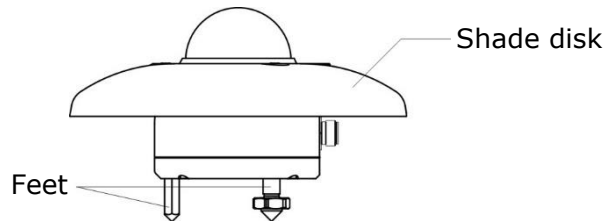

- remove the upper cover by loosening the three fixing knobs;
- remove the plate in the center of the unit by unscrewing the 2 M5x10 Allen screws;
- fix the plate to the pyranometer base with the 2 M5x16 countersunk screws supplied; pay attention that the countersinking of the holes in the plate is on the opposite side to the base of the pyranometer;
- fix the plate with the pyranometer to the unit with the 2 M5x10 Allen screws;

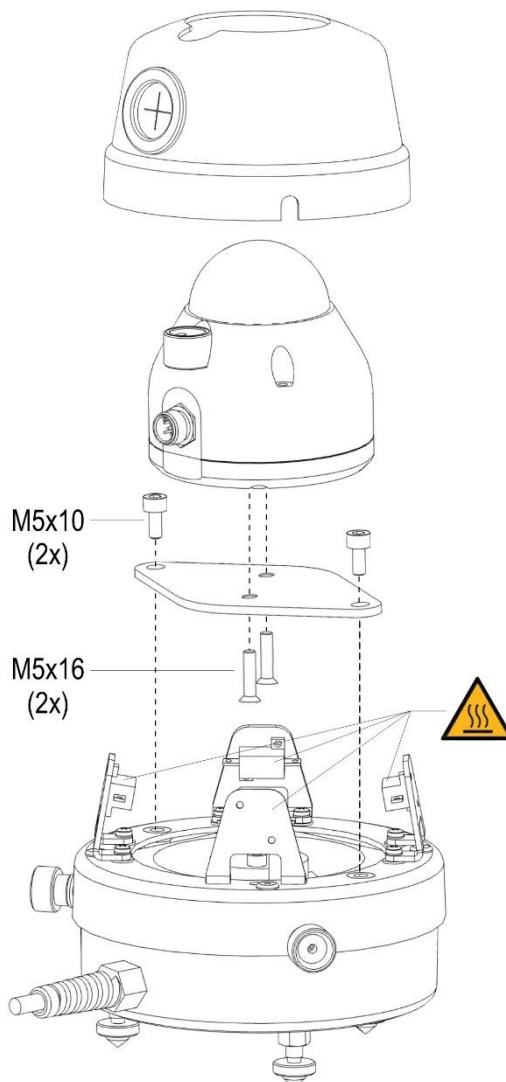

- pass the pyranometer connection cable through the membrane cable gland on the upper cover and attach it to the M12 connector on the pyranometer; the pyranometer must be oriented so that the connector faces the membrane cable gland;
- replace the upper cover and tighten the three fixing knobs.

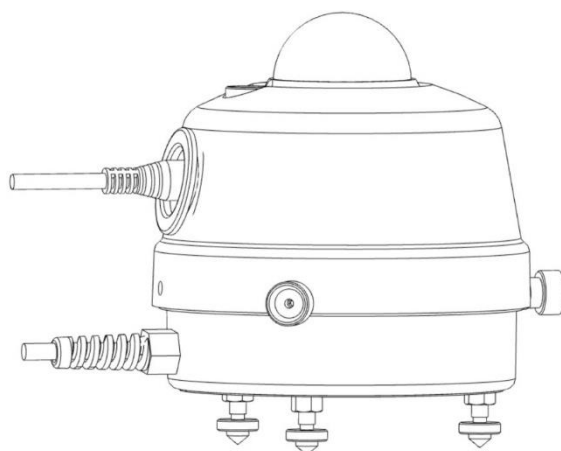

Positioning the unit

For an accurate horizontal positioning, use the levelling device on the pyranometer. The unit has height-adjustable feet for levelling.

Leave at least 2 cm of air between the bottom of the unit and the feet supporting surface to allow adequate ventilation.

The two M6 holes at the bottom of the unit can be used for fixing to a support plate.

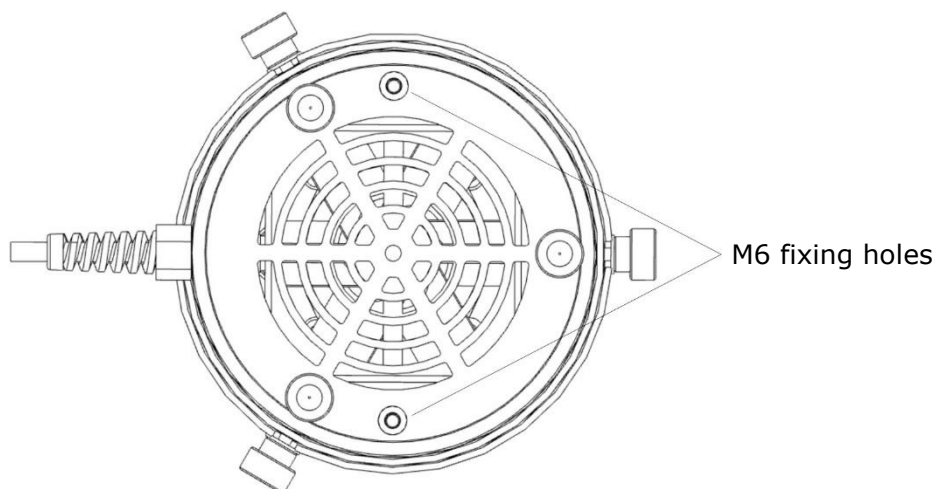

Connections

Function	Wire color
Fan power supply positive	White
Heater 1 power supply positive	Green
Heater 2 power supply positive	Yellow
GND	Brown

Pay attention to respect the polarity of the fan, otherwise the air flow will be in the opposite direction to that expected (bottom up).

4 Use of ventilation and heating

Ventilation is normally always in operation, to keep the temperature of the pyranometer uniform and to prevent dust from settling on the dome.

Instead, the need to activate the heating circuits depends on the ambient temperature. Only one of the two heating circuits can be activated if the climate is not particularly severe; or, both circuits can be activated if the climate is more severe.

The diagram below provides an indication of when heating activation is recommended:

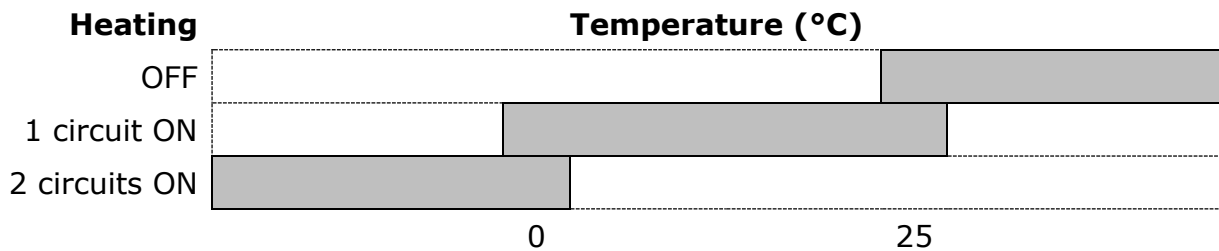

The exact temperature at which to activate the heating can also depend on other climatic factors. For example, the probability of dew forming on the dome is affected by whether the climate is dry or humid. Therefore, the exact activation temperature should be adapted to the place of installation.

When the heating circuits are turned on and off, the pyranometer measurement may be affected by a change in the order of 1...3 W/m², due to the ongoing temperature change. It takes about 20 minutes for the pyranometer to stabilize in the new operating condition; during this period the pyranometer operates normally, but the additional measurement error indicated should be taken into account.

5 Maintenance

Periodically check the cleanliness of the lower grids so that proper airflow is ensured. The maintenance period depends on the degree of pollution of the environment in which the unit is installed.

If necessary, remove the upper shell for thorough cleaning.

6 Safety instructions

The unit proper operation and operating safety can be ensured only in the climatic conditions specified in this manual and if all standard safety measures as well as the specific measures described in this manual are followed.

Do not use the unit in places where there are:

- Corrosive or flammable gases.
- Direct vibrations or shocks to the instrument.
- High-intensity electromagnetic fields, static electricity.

User obligations

The unit operator shall follow the directives and regulations below that refer to the treatment of dangerous materials:

- EU directives on workplace safety.
- National law regulations on workplace safety.
- Accident prevention regulations.

NOTES

WARRANTY

The manufacturer is required to respond to the "factory warranty" only in those cases provided by Legislative Decree 6 September 2005 - n. 206. Each instrument is sold after rigorous inspections; if any manufacturing defect is found, it is necessary to contact the distributor where the instrument was purchased from. During the warranty period (24 months from the date of invoice) any manufacturing defects found will be repaired free of charge. Misuse, wear, neglect, lack or inefficient maintenance as well as theft and damage during transport are excluded. Warranty does not apply if changes, tampering or unauthorized repairs are made on the product. Solutions, probes, electrodes and microphones are not guaranteed as the improper use, even for a few minutes, may cause irreparable damages.

The manufacturer repairs the products that show defects of construction in accordance with the terms and conditions of warranty included in the manual of the product. For any dispute, the competent court is the Court of Padua. The Italian law and the "Convention on Contracts for the International Sales of Goods" apply.

TECHNICAL INFORMATION

The quality level of our instruments is the result of the continuous product development. This may lead to differences between the information reported in the manual and the instrument you have purchased.

We reserve the right to change technical specifications and dimensions to fit the product requirements without prior notice.

DISPOSAL INFORMATION

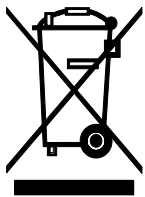

Electrical and electronic equipment marked with specific symbol in compliance with 2012/19/EU Directive must be disposed of separately from household waste. European users can hand them over to the dealer or to the manufacturer when purchasing a new electrical and electronic equipment, or to a WEEE collection point designated by local authorities. Illegal disposal is punished by law.

Disposing of electrical and electronic equipment separately from normal waste helps to preserve natural resources and allows materials to be recycled in an environmentally friendly way without risks to human health.



senseca.com



Senseca Italy S.r.l.
Via Marconi, 5
35030 Selvazzano Dentro (PD)
ITALY
info@senseca.com

